

A
B
MT
D
E
F
G
H
I
J
K
L
M
N
O
P

SECTION **MT**

MANUAL TRANSAXLE

CONTENTS

<p style="text-align: center;">RS6F94R</p> <p>SERVICE INFORMATION 2</p> <p>PRECAUTIONS 2</p> <p style="padding-left: 20px;">Precaution for Supplemental Restraint System (SRS) "AIR BAG" and "SEAT BELT PRE-TENSIONER" 2</p> <p style="padding-left: 20px;">Precaution Necessary for Steering Wheel Rotation After Battery Disconnect 2</p> <p style="padding-left: 20px;">Precaution for Procedure without Cowl Top Cover..... 3</p> <p style="padding-left: 20px;">Precaution 3</p> <p style="padding-left: 20px;">Precaution for Work 3</p> <p>PREPARATION 4</p> <p style="padding-left: 20px;">Special Service Tool 4</p> <p style="padding-left: 20px;">Commercial Service Tool 6</p> <p>NOISE, VIBRATION AND HARSHNESS (NVH) TROUBLESHOOTING 9</p> <p style="padding-left: 20px;">NVH Troubleshooting Chart 9</p> <p>DESCRIPTION 10</p> <p style="padding-left: 20px;">Cross-Sectional View 10</p> <p>M/T OIL 12</p> <p style="padding-left: 20px;">Changing M/T Oil 12</p> <p style="padding-left: 20px;">Checking M/T Oil 12</p> <p>SIDE OIL SEAL 13</p> <p style="padding-left: 20px;">Removal and Installation 13</p>	<p>POSITION SWITCH 14</p> <p style="padding-left: 20px;">Checking 14</p> <p>CONTROL LINKAGE 15</p> <p style="padding-left: 20px;">Component of Shift Selector and Control Cable 15</p> <p style="padding-left: 20px;">Removal and Installation 15</p> <p>AIR BREATHER HOSE 17</p> <p style="padding-left: 20px;">Removal and Installation 17</p> <p>TRANSAXLE ASSEMBLY 18</p> <p style="padding-left: 20px;">Component 18</p> <p style="padding-left: 20px;">Removal and Installation 18</p> <p style="padding-left: 20px;">Disassembly and Assembly 19</p> <p>INPUT SHAFT AND GEARS 37</p> <p style="padding-left: 20px;">Disassembly and Assembly 37</p> <p>MAINSHAFT AND GEARS 42</p> <p style="padding-left: 20px;">Disassembly and Assembly 42</p> <p>REVERSE IDLER SHAFT AND GEARS 47</p> <p style="padding-left: 20px;">Disassembly and Assembly 47</p> <p>FINAL DRIVE 49</p> <p style="padding-left: 20px;">Disassembly and Assembly 49</p> <p>SHIFT CONTROL 51</p> <p style="padding-left: 20px;">Inspection 51</p> <p>SERVICE DATA AND SPECIFICATIONS (SDS) 52</p> <p style="padding-left: 20px;">General Specification 52</p>
---	--

SERVICE INFORMATION

PRECAUTIONS

Precaution for Supplemental Restraint System (SRS) "AIR BAG" and "SEAT BELT PRE-TENSIONER"

INFOID:000000007330286

The Supplemental Restraint System such as "AIR BAG" and "SEAT BELT PRE-TENSIONER", used along with a front seat belt, helps to reduce the risk or severity of injury to the driver and front passenger for certain types of collision. This system includes seat belt switch inputs and dual stage front air bag modules. The SRS system uses the seat belt switches to determine the front air bag deployment, and may only deploy one front air bag, depending on the severity of a collision and whether the front occupants are belted or unbelted. Information necessary to service the system safely is included in the SRS and SB section of this Service Manual.

WARNING:

- To avoid rendering the SRS inoperative, which could increase the risk of personal injury or death in the event of a collision which would result in air bag inflation, all maintenance must be performed by an authorized NISSAN/INFINITI dealer.
- Improper maintenance, including incorrect removal and installation of the SRS can lead to personal injury caused by unintentional activation of the system. For removal of Spiral Cable and Air Bag Module, see the SRS section.
- Do not use electrical test equipment on any circuit related to the SRS unless instructed to in this Service Manual. SRS wiring harnesses can be identified by yellow and/or orange harnesses or harness connectors.

PRECAUTIONS WHEN USING POWER TOOLS (AIR OR ELECTRIC) AND HAMMERS

WARNING:

- When working near the Airbag Diagnosis Sensor Unit or other Airbag System sensors with the Ignition ON or engine running, DO NOT use air or electric power tools or strike near the sensor(s) with a hammer. Heavy vibration could activate the sensor(s) and deploy the air bag(s), possibly causing serious injury.
- When using air or electric power tools or hammers, always switch the Ignition OFF, disconnect the battery, and wait at least 3 minutes before performing any service.

Precaution Necessary for Steering Wheel Rotation After Battery Disconnect

INFOID:000000007330287

NOTE:

- This Procedure is applied only to models with Intelligent Key system and NATS (NISSAN ANTI-THEFT SYSTEM).
- Remove and install all control units after disconnecting both battery cables with the ignition knob in the "LOCK" position.
- Always use CONSULT to perform self-diagnosis as a part of each function inspection after finishing work. If DTC is detected, perform trouble diagnosis according to self-diagnostic results.

For models equipped with the Intelligent Key system and NATS, an electrically controlled steering lock mechanism is adopted on the key cylinder.

For this reason, if the battery is disconnected or if the battery is discharged, the steering wheel will lock and steering wheel rotation will become impossible.

If steering wheel rotation is required when battery power is interrupted, follow the procedure below before starting the repair operation.

OPERATION PROCEDURE

1. Connect both battery cables.

NOTE:

Supply power using jumper cables if battery is discharged.

2. Use the Intelligent Key or mechanical key to turn the ignition switch to the "ACC" position. At this time, the steering lock will be released.
3. Disconnect both battery cables. The steering lock will remain released and the steering wheel can be rotated.
4. Perform the necessary repair operation.

PRECAUTIONS

< SERVICE INFORMATION >

[RS6F94R]

5. When the repair work is completed, return the ignition switch to the "LOCK" position before connecting the battery cables. (At this time, the steering lock mechanism will engage.)
6. Perform a self-diagnosis check of all control units using CONSULT.

Precaution for Procedure without Cowl Top Cover

INFOID:000000007330288

When performing the procedure after removing cowl top cover, cover the lower end of windshield with urethane, etc.

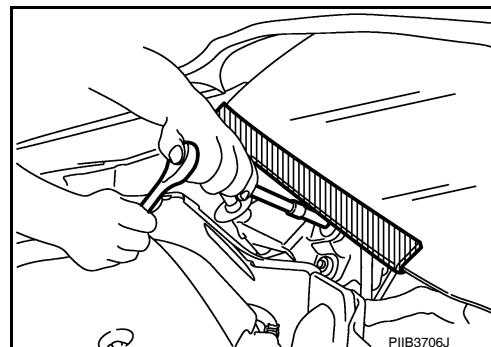

Precaution

INFOID:000000007330289

- If transaxle assembly is removed from the vehicle, always replace CSC (concentric slave cylinder). Installed CSC returns to the original position when removing transaxle assembly. Dust on clutch disc sliding parts may damage CSC seal, and may cause clutch fluid leakage.
- Do not reuse transaxle oil.
- Drain, fill and check transaxle oil with the vehicle on level surface.
- During removal or installation, keep inside of transaxle clear of dust or dirt.
- Check for the correct installation orientation prior to removal or disassembly. If matching marks are required, be certain they do not interfere with the function of the parts they are applied to.
- In principle, tighten bolts or nuts gradually in several steps working diagonally from inside to outside. If tightening sequence is specified, follow it.
- Be careful not to damage the sliding surfaces and mating surfaces of parts.

Precaution for Work

INFOID:000000007793165

- When removing or disassembling each component, be careful not to damage or deform it. If a component may be subject to interference, be sure to protect it with a shop cloth.
- When removing (disengaging) components with a screwdriver or similar tool, be sure to wrap the component with a shop cloth or vinyl tape to protect it.
- Protect the removed parts with a shop cloth and prevent them from being dropped.
- Replace a deformed or damaged clip.
- If a part is specified as a non-reusable part, always replace it with new one.
- Be sure to tighten bolts and nuts securely to the specified torque.
- After installation is complete, be sure to check that each part works properly.
- Follow the steps below to clean components.
 - Water soluble dirt: Dip a soft cloth into lukewarm water, and wring the water out of the cloth to wipe the dirty area.
Then rub with a soft and dry cloth.
 - Oily dirt: Dip a soft cloth into lukewarm water with mild detergent (concentration: within 2 to 3%), and wipe the dirty area.
Then dip a cloth into fresh water, and wring the water out of the cloth to wipe the detergent off. Then rub with a soft and dry cloth.
- Do not use organic solvent such as thinner, benzene, alcohol, or gasoline.
- For genuine leather seats, use a genuine leather seat cleaner.

PREPARATION

< SERVICE INFORMATION >

[RS6F94R]

PREPARATION

Special Service Tool

INFOID:000000007330290

The actual shapes of Kent-Moore tools may differ from those of special service tools illustrated here.

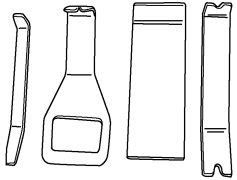
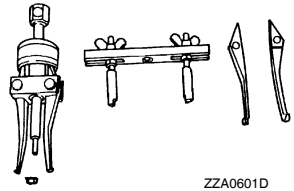
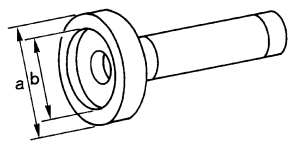
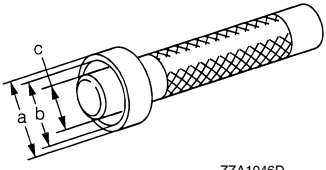
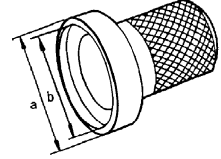
Tool number (Kent-Moore No.) Tool name	Description
<p>— (J-46534) Trim tool set</p> <div style="text-align: center;">  <p style="font-size: small;">AWJIA0483ZZ</p> </div>	<p>For removing trim</p>
<p>KV381054S0 (J-34286) Puller</p> <div style="text-align: center;">  <p style="font-size: small;">ZZA0601D</p> </div>	<p>Removing mainshaft front bearing outer race</p>
<p>KV38100200 (—) Drift</p> <div style="text-align: center;">  <p style="font-size: small;">ZZA1143D</p> </div>	<ul style="list-style-type: none"> • Installing mainshaft front bearing outer race • Installing mainshaft rear bearing outer race • Installing differential side bearing outer race (clutch housing side) <p>a: 65 mm (2.56 in) dia. b: 49 mm (1.93 in) dia.</p>
<p>ST33220000 (—) Drift</p> <div style="text-align: center;">  <p style="font-size: small;">ZZA1046D</p> </div>	<p>Installing input shaft oil seal</p> <p>a: 37 mm (1.46 in) dia. b: 31 mm (1.22 in) dia. c: 22 mm (0.87 in) dia.</p>
<p>ST33400001 (J-26082) Drift</p> <div style="text-align: center;">  <p style="font-size: small;">ZZA0814D</p> </div>	<p>Installing differential side bearing outer race (transaxle case side)</p> <p>a: 60 mm (2.36 in) dia. b: 47 mm (1.85 in) dia.</p>

PREPARATION

< SERVICE INFORMATION >

[RS6F94R]

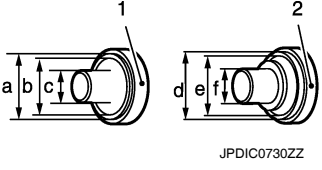
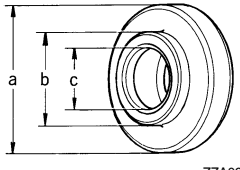
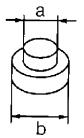
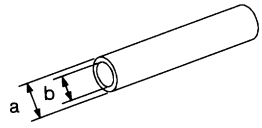
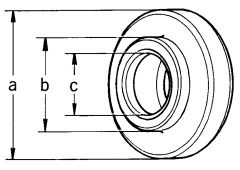
Tool number (Kent-Moore No.) Tool name	Description
KV3250QAA (Renault SST: B.vi 1666) Drift set	Installing differential side oil seal 1. — (Stamping number: B.vi 1666-A) Drift a: 54.3 mm (2.138 in) dia. b: 45 mm (1.77 in) dia. c: 26.6 mm (1.047 in) dia. 2. — (Stamping number: B.vi 1666-B) Drift a: 54.3 mm (2.138 in) dia. b: 45 mm (1.77 in) dia. c: 26.6 mm (1.047 in) dia.
	
ST36720030 (—) Drift	<ul style="list-style-type: none"> • Installing input shaft front bearing • Installing mainshaft front bearing inner race a: 70 mm (2.76 in) dia. b: 40 mm (1.57 in) dia. c: 29 mm (1.14 in) dia.
	
ST33052000 (—) Drift	<ul style="list-style-type: none"> • Removing mainshaft rear bearing inner race • Removing 6th main gear • Removing 5th main gear • Removing 4th main gear • Removing 1st main gear • Removing 1st-2nd synchronizer assembly • Removing 2nd main gear • Removing bushing • Removing 3rd main gear • Removing mainshaft front bearing inner race a: 22 mm (0.87 in) dia. b: 28 mm (1.10 in) dia.
	
KV32102700 (—) Drift	<ul style="list-style-type: none"> • Installing bushing • Installing 2nd main gear • Installing 3rd main gear • Installing 4th main gear • Installing 5th main gear • Installing 6th main gear a: 54 mm (2.13 in) dia. b: 32 mm (1.26 in) dia.
	
ST30901000 (J-26010-01) Drift	Installing mainshaft rear bearing inner race a: 79 mm (3.11 in) dia. b: 45 mm (1.77 in) dia. c: 35.2 mm (1.386 in) dia.
	

A
B
MT
D
E
F
G
H
I
J
K
L
M
N
O
P

PREPARATION

< SERVICE INFORMATION >

[RS6F94R]

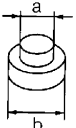
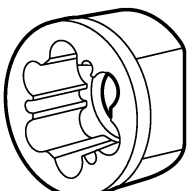
Tool number (Kent-Moore No.) Tool name	Description
ST33061000 (J-8107-2) Drift	Removing differential side bearing inner race (clutch housing side) a: 28.5 mm (1.122 in) dia. b: 38 mm (1.50 in) dia.
 ZZA0969D	
KV32300QAM (Renault SST: B.vi 1823) Drift	Removing and installing input shaft rear bearing bolt
 PCB2078J	

Commercial Service Tool

INFOID:000000007330291

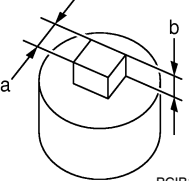
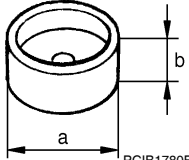
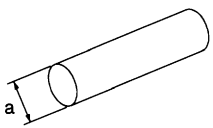
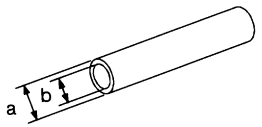
Tool name	Description
Socket	Removing and installing drain plug a: 8 mm (0.31 in) b: 5 mm (0.20 in)
 PCB1776E	
Spacer	Removing mainshaft front bearing outer race a: 25 mm (0.98 in) dia. b: 25 mm (0.98 in)
 PCB1780E	
Drift	Installing bushing a: 17 mm (0.67 in) dia.
 S-NT063	
Drift	Installing input shaft front bearing a: 35 mm (1.38 in) dia. b: 25 mm (0.98 in) dia.
 S-NT065	

PREPARATION

< SERVICE INFORMATION >

[RS6F94R]

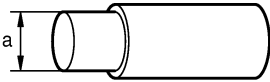
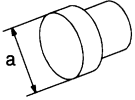
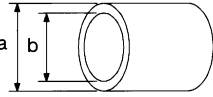
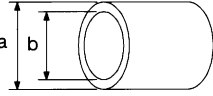
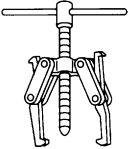
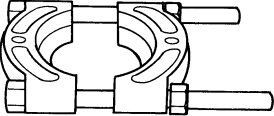
Tool name	Description
Drift  PCIB1779E	Removing input shaft rear bearing a: 24 mm (0.94 in) dia.
Drift  NT109	<ul style="list-style-type: none"> • Removing differential side bearing inner race (transaxle case side) • Installing input shaft rear bearing a: 43 mm (1.69 in) dia.
Drift  S-NT474	Installing differential side bearing inner race (clutch housing side) a: 45 mm (1.77 in) dia. b: 39 mm (1.54 in) dia.
Drift  S-NT474	Installing differential side bearing inner race (transaxle case side) a: 52 mm (2.05 in) dia. b: 45 mm (1.77 in) dia.
Puller  NT077	Removing differential side bearing inner race (clutch housing side) Removing differential side bearing inner race (transaxle case side)
Puller  ZZB0823D	<ul style="list-style-type: none"> • Removing differential side bearing inner race (clutch housing side) • Removing differential side bearing inner race (transaxle case side) • Removing input shaft rear bearing • Removing input shaft front bearing • Removing mainshaft rear bearing inner race • Removing 6th main gear • Removing 4th main gear • Removing 5th main gear • Removing 1st main gear • Removing 1st - 2nd synchronizer hub assembly • Removing 2nd main gear • Removing 3rd main gear • Removing mainshaft front bearing outer race

A

B

MT

D

E

F

G

H

I

J

K

L

M

N

O

P

PREPARATION

< SERVICE INFORMATION >

[RS6F94R]

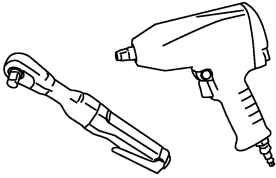
Tool name	Description
<p data-bbox="159 197 259 222">Remover</p>  <p data-bbox="824 415 881 432">S-NT134</p>	<ul data-bbox="1008 197 1422 279" style="list-style-type: none">• Removing bushing• Removing mainshaft rear bearing outer race
<p data-bbox="159 449 272 474">Power tool</p>  <p data-bbox="824 667 898 684">PBIC0190E</p>	<ul data-bbox="1008 449 1279 474" style="list-style-type: none">• Loosening bolts and nuts

NOISE, VIBRATION AND HARSHNESS (NVH) TROUBLESHOOTING

< SERVICE INFORMATION >

[RS6F94R]

NOISE, VIBRATION AND HARSHNESS (NVH) TROUBLESHOOTING

NVH Troubleshooting Chart

INFOID:000000007330292

Use the chart below to help you find the cause of the symptom. The numbers indicate the order of the inspection. If necessary, repair or replace these parts.

Reference page		MT-12		MT-18		MT-18	MT-15	MT-51	MT-18				
SUSPECTED PARTS (Possible cause)		OIL (Oil level is low.)	OIL (Wrong oil.)	OIL (Oil level is high.)	GASKET (Damaged)	OIL SEAL (Worn or damaged)	O-RING (Worn or damaged)	SHIFT CONTROL LINKAGE (Worn)	SHIFT FORK (Worn)	GEAR (Worn or damaged)	BEARING (Worn or damaged)	BAULK RING (Worn or damaged)	INSERT SPRING (Damaged)
Symptoms	Noise	1	2							3	3		
	Oil leakage		3	1	2	2	2						
	Hard to shift or will not shift		1	1				2				3	3
	Jumps out of gear							1	3	3			

A
B
C
D
E
F
G
H
I
J
K
L
M
N
O
P

MT

DESCRIPTION

< SERVICE INFORMATION >

[RS6F94R]

DESCRIPTION

Cross-Sectional View

INFOID:000000007330293

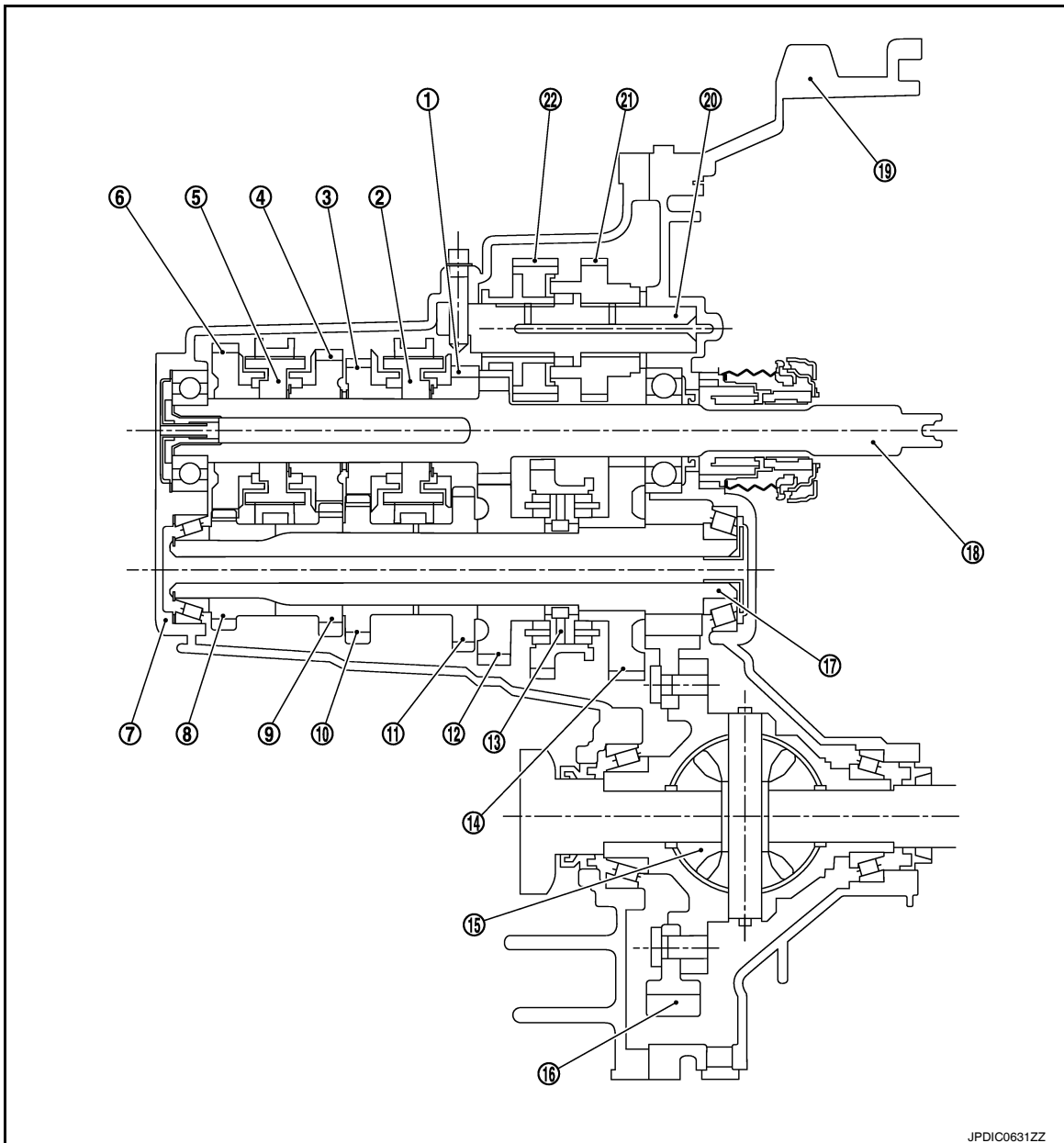

- | | | |
|-----------------------------------|----------------------------------|------------------------|
| 1. 3rd input gear | 2. 3rd-4th synchronizer assembly | 3. 4th input gear |
| 4. 5th input gear | 5. 5th-6th synchronizer assembly | 6. 6th input gear |
| 7. Transaxle case | 8. 6th main gear | 9. 5th main gear |
| 10. 4th main gear | 11. 3rd main gear | 12. 2nd main gear |
| 13. 1st-2nd synchronizer assembly | 14. 1st main gear | 15. Differential |
| 16. Final gear | 17. Mainshaft | 18. Input shaft |
| 19. Clutch housing | 20. Reverse idler shaft | 21. Reverse input gear |
| 22. Reverse output gear | | |

TRIPLE-CONE SYNCHRONIZER

DESCRIPTION

[RS6F94R]

< SERVICE INFORMATION >

Triple-cone synchronizer is used for the 1st and the 2nd gears to reduce operating force of the shift selector.

- 1st main gear (1)
- 1st-2nd coupling sleeve (2)
- Insert key (3)
- Outer baulk ring (4)
- 2nd main gear (5)
- Synchronizer cone (6)
- Inner baulk ring (7)
- 1st-2nd synchronizer hub (8)

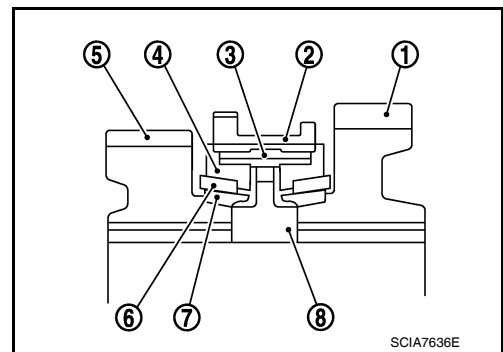

REVERSE GEAR NOISE PREVENTION FUNCTION (SYNCHRONIZING METHOD)

Reverse gear assembly consists of reverse input gear, return spring, reverse baulk ring and reverse output gear. When the shift selector is moved to the reverse position, the construction allows smooth shift operation by stopping the reverse idler shaft rotation by frictional force of synchronizer.

- Reverse fork rod (1)
- Reverse output gear (2)
- Return spring (3)
- Reverse baulk ring (4)
- Reverse input gear (5)

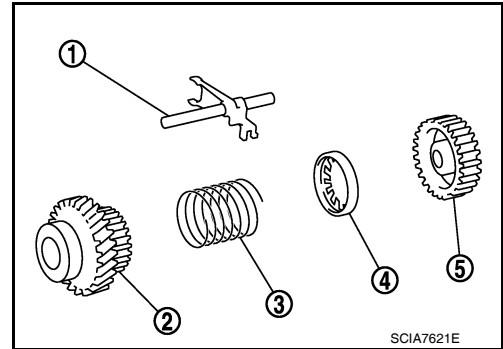

A
B
MT
D
E
F
G
H
I
J
K
L
M
N
O
P

M/T OIL

Changing M/T Oil

INFOID:000000007330294

DRAINING

1. Start engine and let it run to warm up transaxle.
 2. Stop engine. Remove drain plug (1) and drain oil.
 3. Install a new gasket onto drain plug (1) and install it into transaxle. Tighten drain plug to specification. Refer to [MT-18, "Component"](#).
- CAUTION:**
Do not reuse gasket.

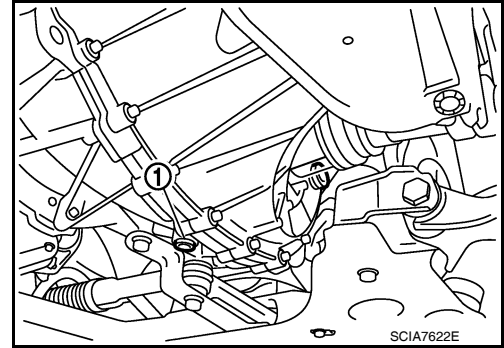

FILLING

1. Remove filler plug (1). Fill with new oil until oil level reaches the specified limit at filler plug hole as shown.
- Oil grade and capacity**
: Refer to [MA-13, "Fluids and Lubricants"](#)
2. After refilling oil, check oil level. Install a new gasket on filler plug (1), then install it into transaxle. Tighten filler plug to specification. Refer to [MT-18, "Component"](#).
- CAUTION:**
Do not reuse gasket.

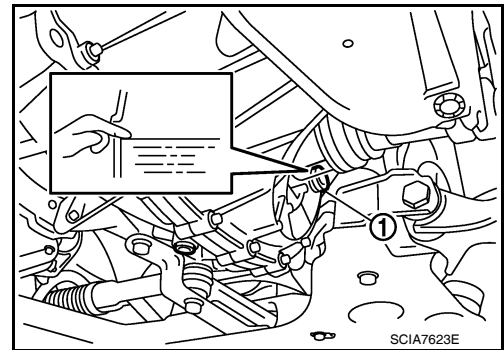

Checking M/T Oil

INFOID:000000007330295

OIL LEAKAGE AND OIL LEVEL

1. Make sure that oil is not leaking from transaxle or around it.
 2. Remove filler plug (1) and check oil level at filler plug hole as shown.
- CAUTION:**
Do not start engine while checking oil level.
3. Install a new gasket onto filler plug (1) and install it into transaxle. Tighten filler plug to specification. Refer to [MT-18, "Component"](#).
- CAUTION:**
Do not reuse gasket.

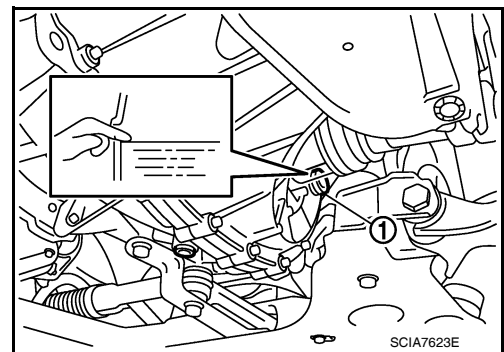

SIDE OIL SEAL

Removal and Installation

INFOID:000000007330297

REMOVAL

1. Remove front drive shafts from transaxle assembly. Refer to [FAX-9, "Removal and Installation \(Left Side\)"](#) and [FAX-10, "Removal and Installation \(Right Side\)"](#).

2. Remove differential side oil seal (1) using a suitable tool.

CAUTION:

Be careful not to damage transaxle case and clutch housing.

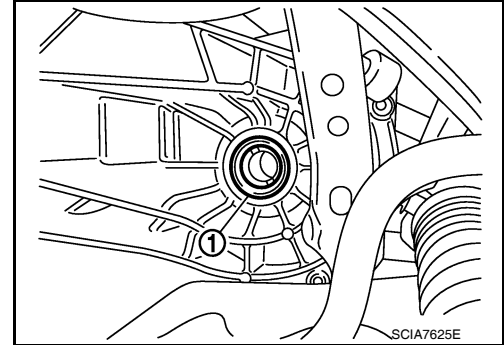

INSTALLATION

Installation is in the reverse order of removal.

- Install differential side oil seal (1) to clutch housing and transaxle case using Tool.

CAUTION:

Do not reuse oil seal.

Tool number : KV32500QAA (B.vi 1666-B)

- (A): Transaxle case side
- (B): Clutch housing side

Dimension (L1) : 1.2 - 1.8 mm (0.047 - 0.071 in)

Dimension (L2) : 2.7 - 3.3 mm (0.106 - 0.130 in)

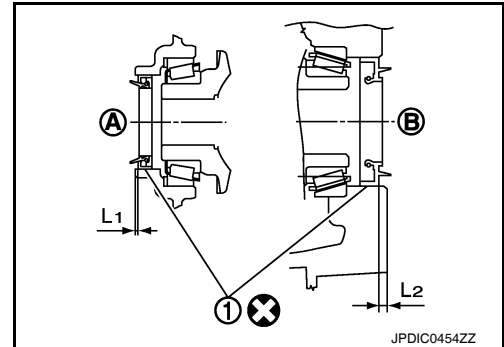

CAUTION:

- Do not reuse differential oil seal
- Do not incline differential oil seal.
- Do not damage clutch housing and transaxle case.
- Check oil level after installation. Refer to [MT-12, "Checking M/T Oil"](#).

A
B
MT
D
E
F
G
H
I
J
K
L
M
N
O
P

POSITION SWITCH

[RS6F94R]

< SERVICE INFORMATION >

POSITION SWITCH

Checking

INFOID:000000007330298

NOTE:

For removal and installation of the switches, refer to [MT-19. "Disassembly and Assembly"](#)

BACK-UP LAMP SWITCH

- Check continuity between terminals 1 and 2.

Gear position	Continuity
Reverse	Yes
Except reverse	No

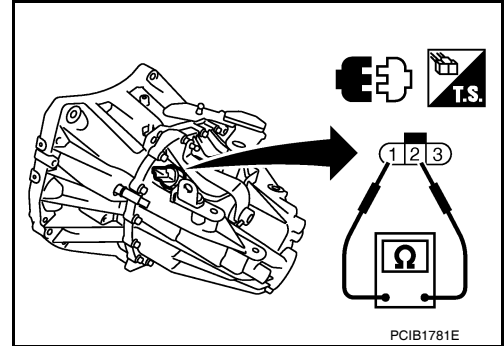

PARK/NEUTRAL POSITION SWITCH

- Check continuity between terminals 2 and 3.

Gear position	Continuity
Neutral	Yes
Except neutral	No

CONTROL LINKAGE

[RS6F94R]

< SERVICE INFORMATION >

CONTROL LINKAGE

Component of Shift Selector and Control Cable

INFOID:000000007330299

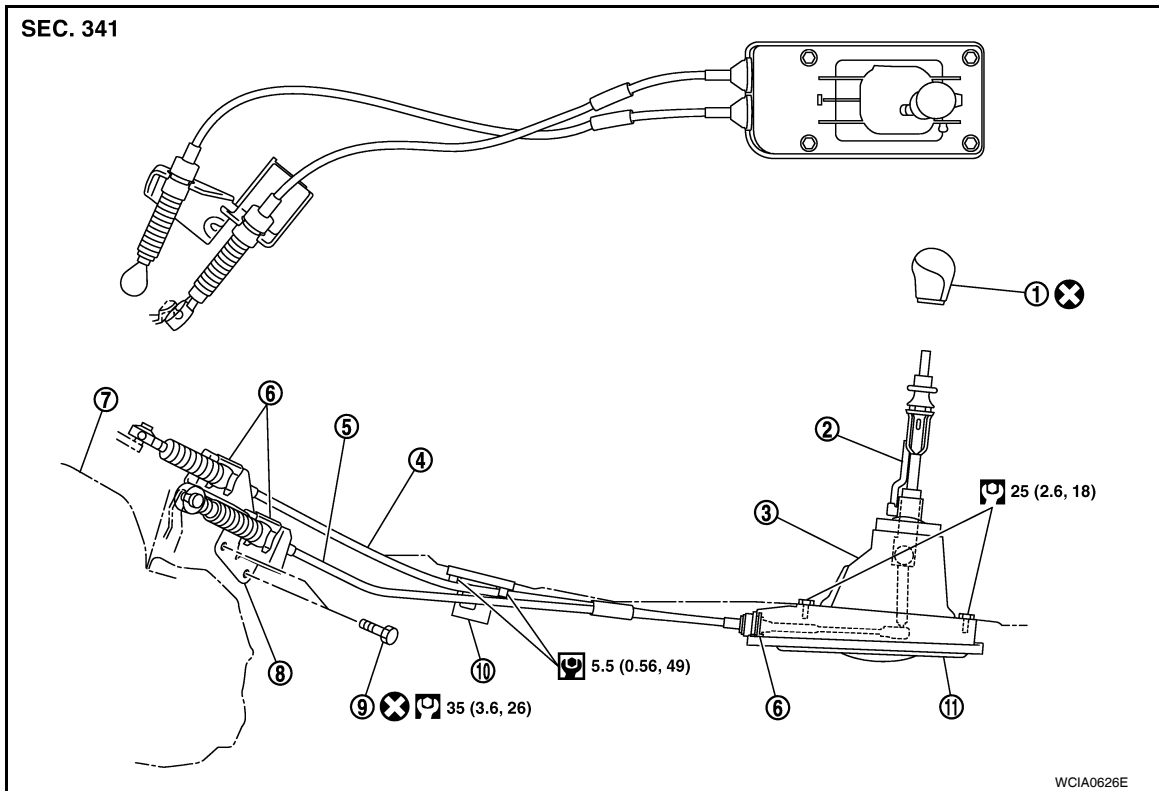

- | | | |
|---------------------------|-------------------------|--------------------------------|
| 1. Shift selector handle | 2. Shift selector | 3. M/T shift selector assembly |
| 4. Select cable | 5. Shift selector cable | 6. Lock plate |
| 7. Clutch housing | 8. Cable bracket | 9. Tapping bolt |
| 10. Cable support bracket | 11. Adapter plate | |

Removal and Installation

INFOID:000000007330300

REMOVAL

1. Remove battery. Refer to [SC-7, "Removal and Installation"](#).
2. Remove air duct (front), air duct (Inlet) and air cleaner case. Refer to [EM-16, "Removal and Installation"](#).
3. Remove shift selector cable from control shaft shift lever.
4. Remove select cable according to the following.
 - a. Move stopper (1) to the unlocked position.

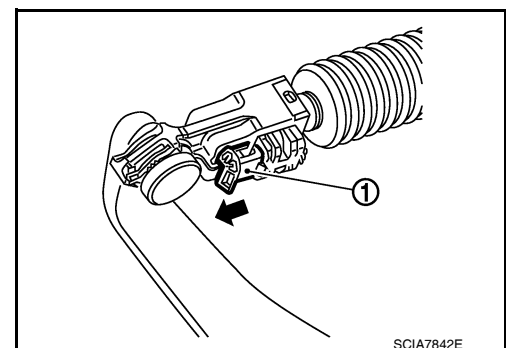

CONTROL LINKAGE

[RS6F94R]

< SERVICE INFORMATION >

- b. Pull the release button (1) of select cable (2) and then remove it from control shaft select lever (3).
5. Move shift selector to neutral position.
6. Remove shift selector handle.
7. Remove center console assembly. Refer to [IP-12, "Removal and Installation"](#).
8. Remove M/T shift selector assembly bolts.
9. Remove exhaust front tube, center muffler and heat plate. Refer to [EX-5, "Removal and Installation"](#).
10. Remove cable support bracket.
11. Remove select cable and shift selector cable from cable bracket.
12. Remove M/T shift selector assembly from the vehicle.

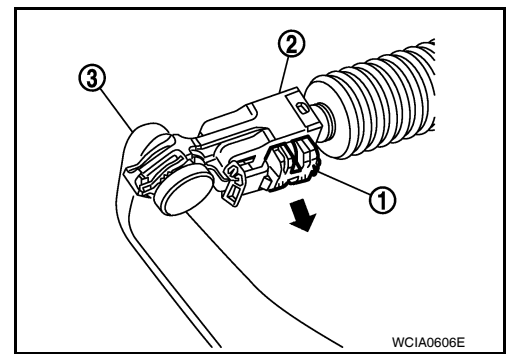

INSTALLATION

Installation is in the reverse order of removal.

NOTE:

Self-tapping bolts are used to attach cables to the clutch housing.

- Securely assemble each cable and lever of control shaft.
- Be careful about the installation direction, and push shift selector handle onto shift selector.

CAUTION:

Do not reuse shift selector handle.

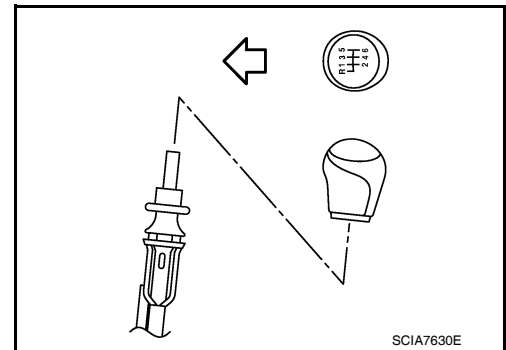

- Make sure that the front/rear pawls (1) of M/T shift selector assembly are in contact with flange of the floor (2).
- When shift selector is moved to 1st-2nd side and 5th-6th side, confirm shift selector returns to neutral position smoothly.
- When shift selector is moved to each position, make sure there is no binding or disconnection in each boot.

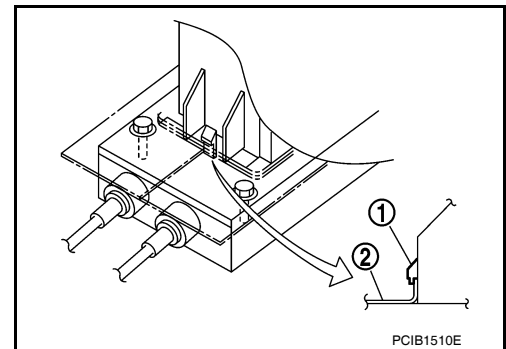

- Move stopper (1) to lock position when installing the shift cable onto the control shaft shift lever.

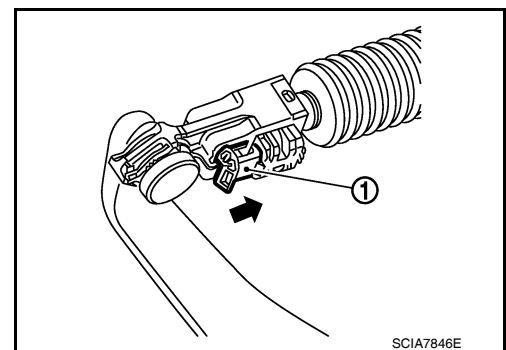

AIR BREATHER HOSE

< SERVICE INFORMATION >

[RS6F94R]

AIR BREATHER HOSE

Removal and Installation

INFOID:000000007330301

COMPONENTS

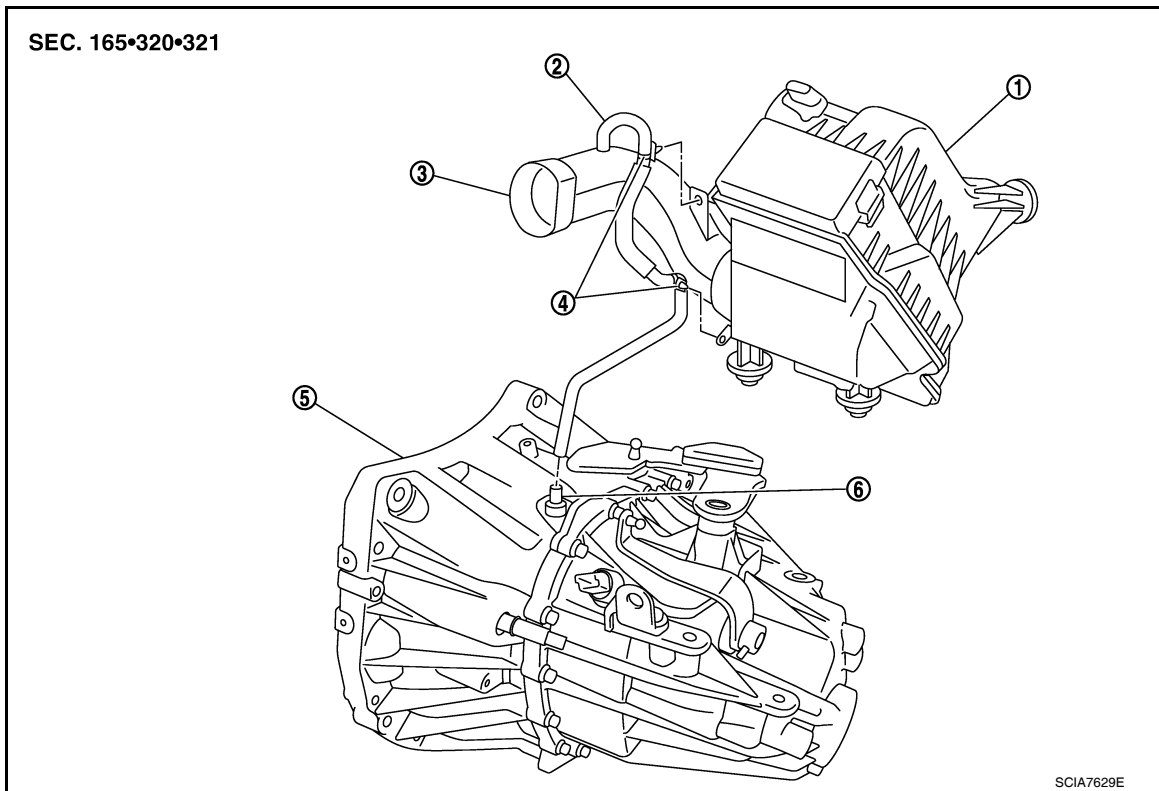

- | | | |
|---------------------|-----------------------|----------------------|
| 1. Air cleaner case | 2. Air breather hose | 3. Air duct (inlet) |
| 4. Clip | 5. Transaxle assembly | 6. Two way connector |

REMOVAL

1. Remove battery. Refer to [SC-7. "Removal and Installation"](#).
2. Remove air duct (front), air duct (inlet) and air cleaner case. Refer to [EM-16. "Removal and Installation"](#).
3. Remove air breather hose.

CAUTION:

When air breather hose is removed, be sure to hold two way connector securely.

INSTALLATION

Installation is in the reverse order of removal.

- When installing air breather hose on two way connector, aim paint mark face toward the vehicle front.
- When installing air breather hose on two way connector, push it until it hits transaxle case.
- When installing air breather hose to air duct and air cleaner case, make sure that clips are fully inserted.

CAUTION:

Make sure air breather hose is not collapsed or blocked due to folding or bending when installed.

TRANSAXLE ASSEMBLY

< SERVICE INFORMATION >

[RS6F94R]

TRANSAXLE ASSEMBLY

Component

INFOID:000000007330302

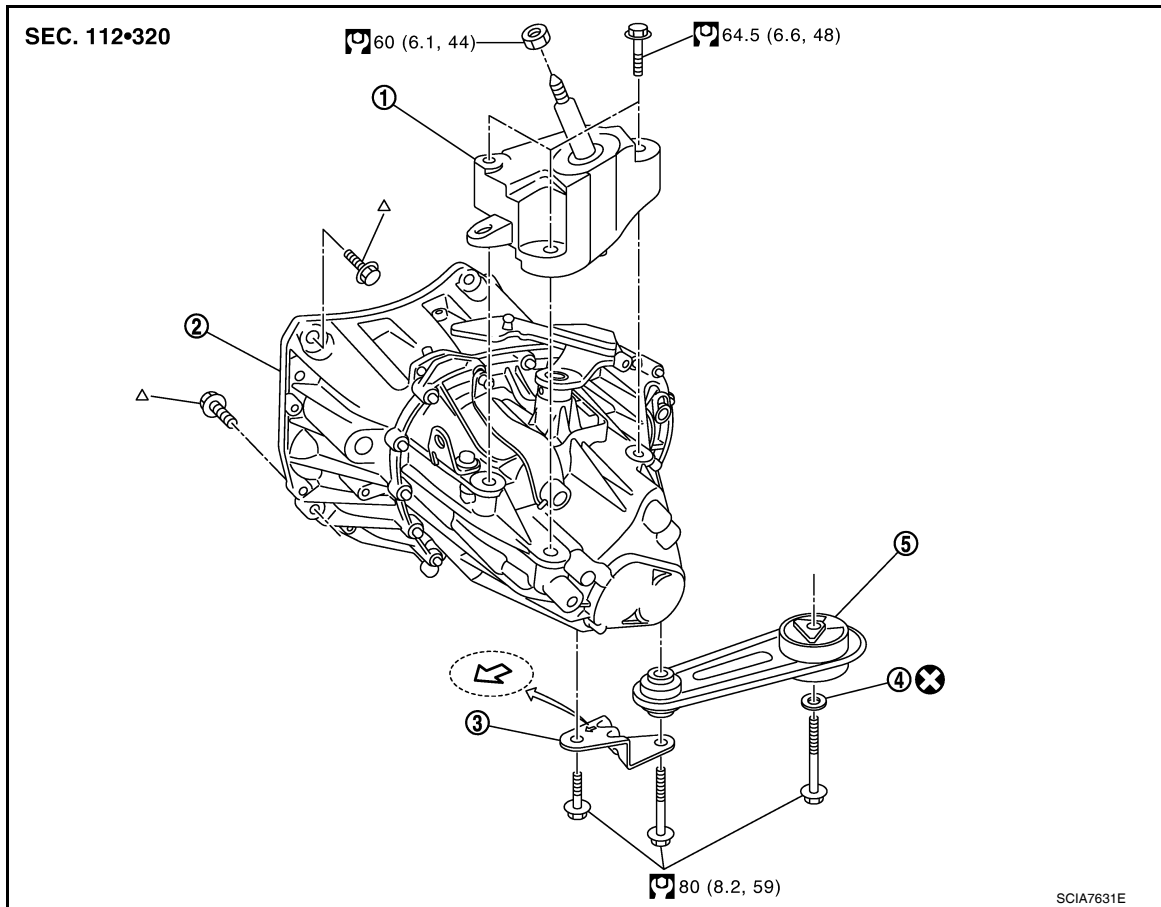

1. LH engine mount bracket (transaxle side) 2. Transaxle assembly 3. Rear engine mount bracket
4. Washer 5. Rear torque rod ← Front

Δ: Refer to [MT-18, "Removal and Installation"](#).

Removal and Installation

INFOID:000000007330303

CAUTION:

If transaxle assembly is removed from the vehicle, always replace CSC (Concentric Slave Cylinder). Inserted CSC returns to the original position when removing transaxle assembly. Dust on clutch disc sliding parts may damage CSC seal, and may cause clutch fluid leakage.

NOTE:

When removing components such as hoses, tubes/lines, etc., cap or plug openings to prevent fluid from spilling.

REMOVAL

1. Drain clutch fluid and remove clutch tube from CSC. Refer to [CL-12, "Removal and Installation"](#).
CAUTION:
Do not depress clutch pedal during removal procedure.
2. Remove engine and transaxle assembly. Refer to [EM-78, "Removal and Installation"](#).
3. Remove starter motor. Refer to [SC-19, "Removal and Installation"](#).
4. Remove transaxle assembly to engine bolts.
5. Separate transaxle assembly from engine.

INSTALLATION

TRANSAXLE ASSEMBLY

[RS6F94R]

< SERVICE INFORMATION >

Installation is in the reverse order of removal.

- If transaxle is removed from the vehicle, always replace CSC. Refer to [CL-12, "Removal and Installation"](#).
- When installing the transaxle assembly to the engine, install the bolts as shown.

CAUTION:

When installing transaxle assembly, be careful not to bring transaxle input shaft into contact with clutch cover.

Bolt No.	1	2
Quantity	3	6
Bolt length "ℓ" mm (in)	60 (2.36)	50 (1.97)
Tightening torque N·m (kg·m, ft·lb)	62.0 (6.3, 46)	

(A): M/T to engine

(B): Engine to M/T

- Bleed the air from the clutch hydraulic system. Refer to [CL-9, "Air Bleeding Procedure"](#).
- After installation, check oil level, and check for leaks and loose mechanisms. Refer to [MT-12, "Checking M/T Oil"](#).

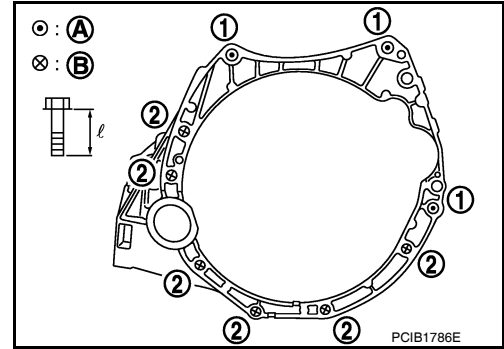

Disassembly and Assembly

INFOID:000000007330304

COMPONENTS

Case and Housing Components

TRANSAXLE ASSEMBLY

< SERVICE INFORMATION >

[RS6F94R]

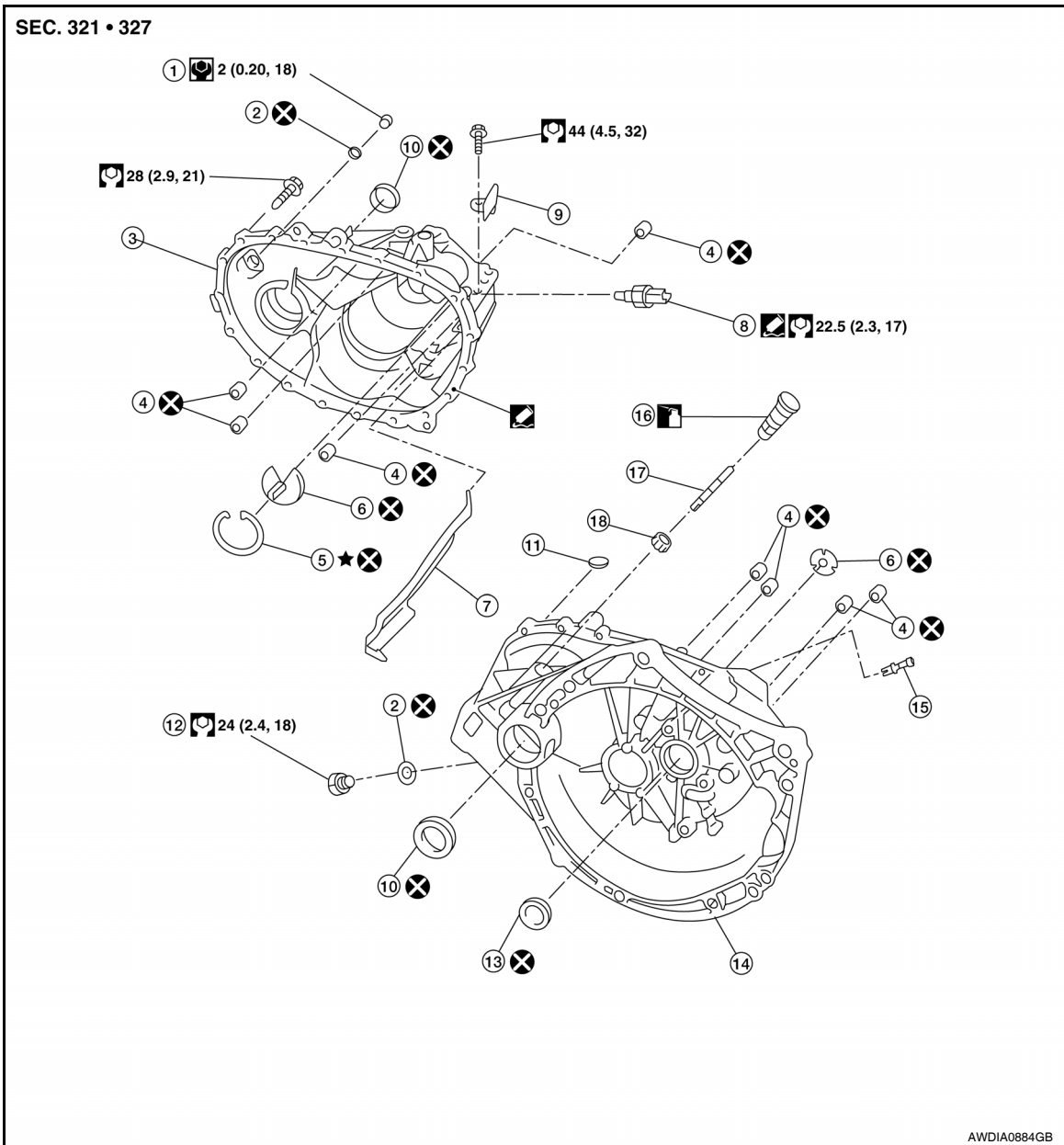

- | | | |
|--------------------------------|--------------------|-----------------------|
| 1. Filler plug | 2. Gasket | 3. Transaxle case |
| 4. Bushing | 5. Snap ring | 6. Oil channel |
| 7. Oil gutter | 8. Position switch | 9. Bracket |
| 10. Differential side oil seal | 11. Magnet | 12. Drain plug |
| 13. Input shaft oil seal | 14. Clutch housing | 15. Two way connector |
| 16. Plug | 17. Pinion shaft | 18. Pinion gear |

Use specified transaxle fluid. Refer to [MA-13. "Fluids and Lubricants"](#)

Apply Genuine Liquid Gasket, Three Bond 1215 or an equivalent.

Gear Components

TRANSAXLE ASSEMBLY

< SERVICE INFORMATION >

[RS6F94R]

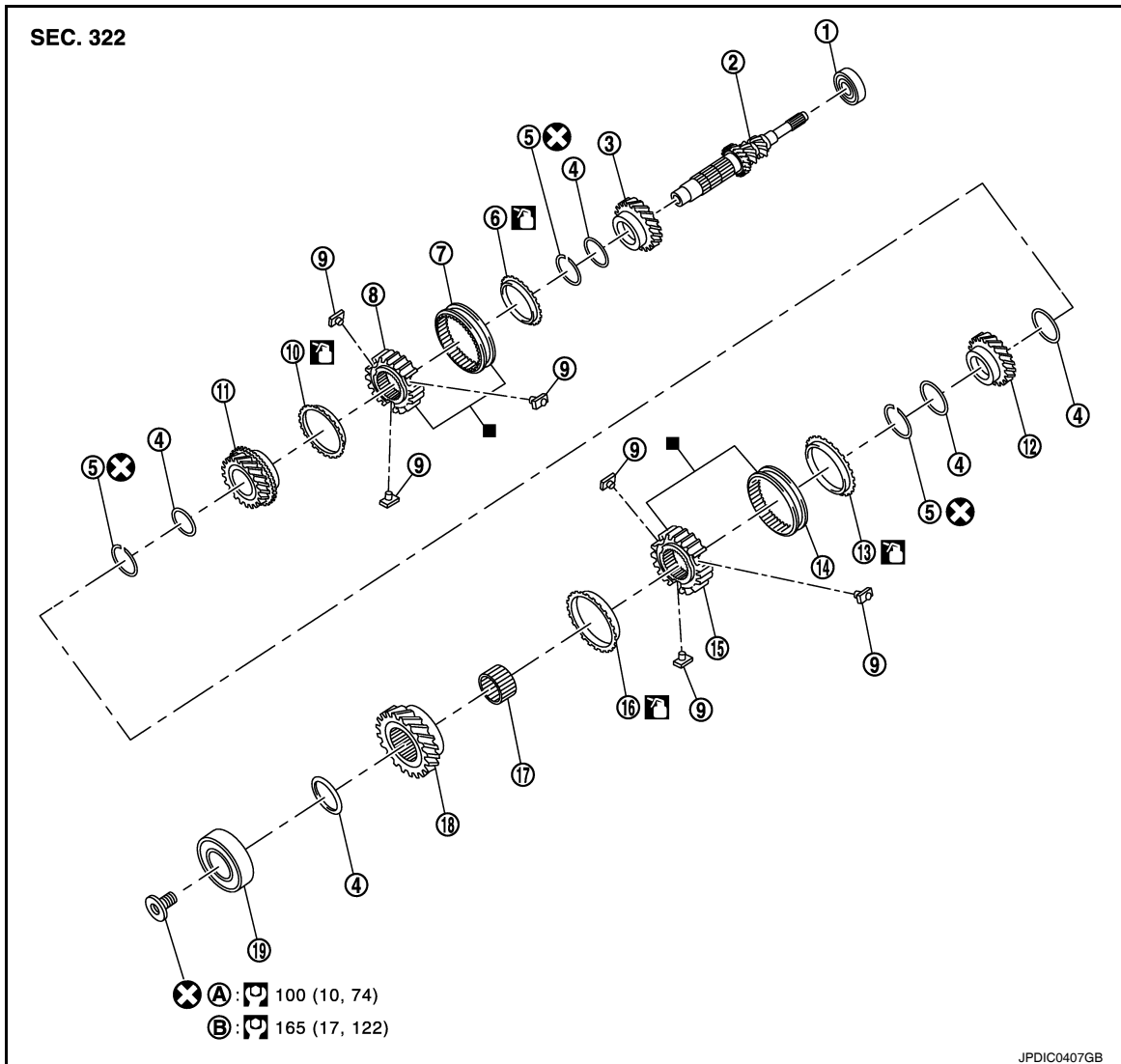

- | | | |
|------------------------------|-----------------------------|------------------------------|
| 1. Input shaft front bearing | 2. Input shaft | 3. 3rd input gear |
| 4. Spacer | 5. Snap ring | 6. 3rd baulk ring |
| 7. 3rd-4th coupling sleeve | 8. 3rd-4th synchronizer hub | 9. Insert key |
| 10. 4th baulk ring | 11. 4th input gear | 12. 5th input gear |
| 13. 5th baulk ring | 14. 5th-6th coupling sleeve | 15. 5th-6th synchronizer hub |
| 16. 6th baulk ring | 17. Needle bearing | 18. 6th input gear |
| 19. Input shaft rear bearing | | |
- A: First step
B: Final step

: Apply gear oil.

: Replace the parts as a set.

A

B

MT

D

E

F

G

H

I

J

K

L

M

N

O

P

TRANSAXLE ASSEMBLY

< SERVICE INFORMATION >

[RS6F94R]

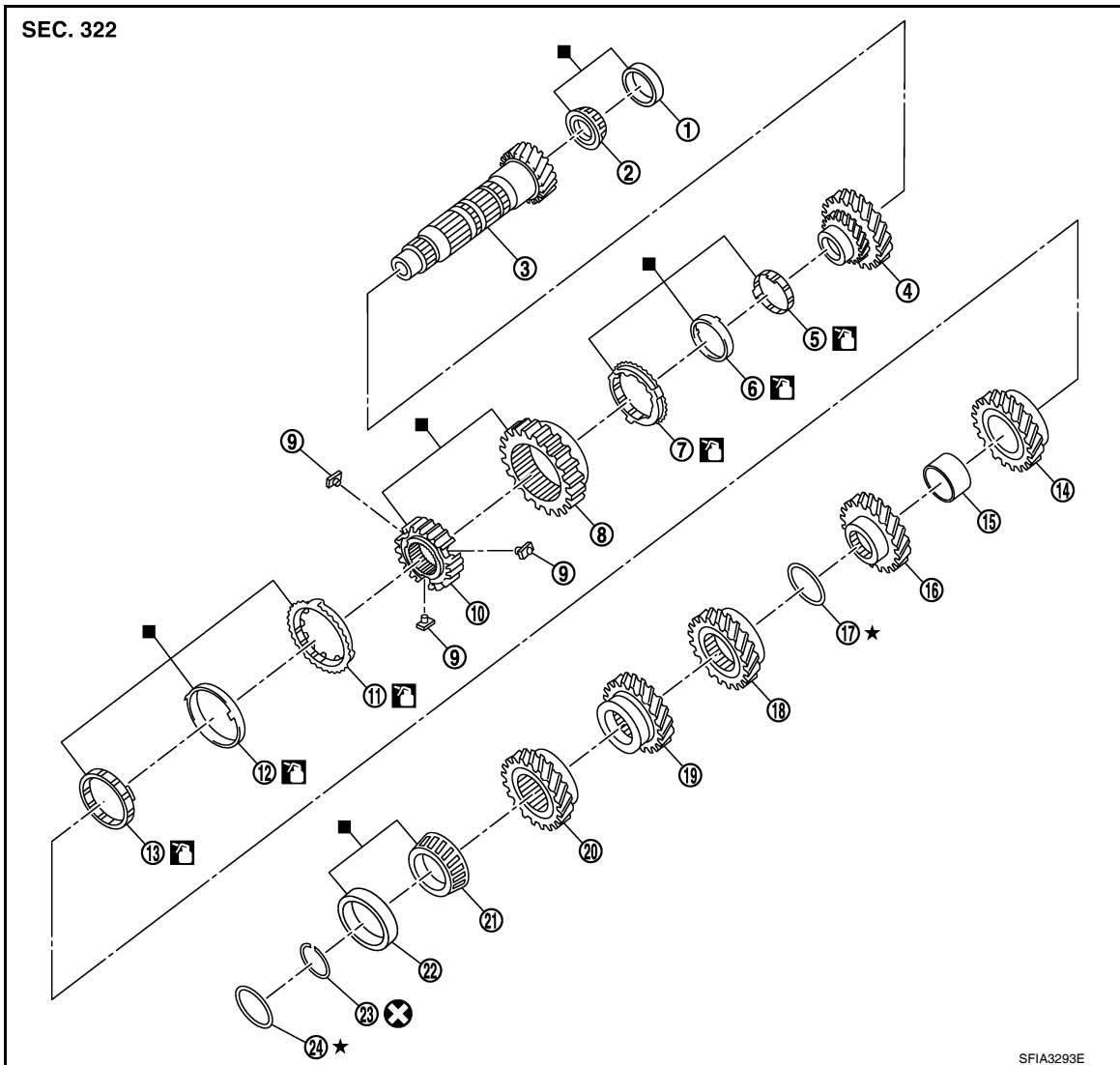

- | | | |
|---------------------------------------|---------------------------------------|---|
| 1. Mainshaft front bearing outer race | 2. Mainshaft front bearing inner race | 3. Mainshaft |
| 4. 1st main gear | 5. 1st inner baulk ring | 6. 1st synchronizer cone |
| 7. 1st outer baulk ring | 8. 1st-2nd coupling sleeve | 9. Insert key |
| 10. 1st-2nd synchronizer hub | 11. 2nd outer baulk ring | 12. 2nd synchronizer cone |
| 13. 2nd inner baulk ring | 14. 2nd main gear | 15. Bushing |
| 16. 3rd main gear | 17. Mainshaft adjusting shim | 18. 4th main gear |
| 19. 5th main gear | 20. 6th main gear | 21. Mainshaft rear bearing inner race |
| 22. Mainshaft rear bearing outer race | 23. Snap ring | 24. Mainshaft rear bearing adjusting shim |

: Apply gear oil.

: Replace the parts as a set.

TRANSAXLE ASSEMBLY

< SERVICE INFORMATION >

[RS6F94R]

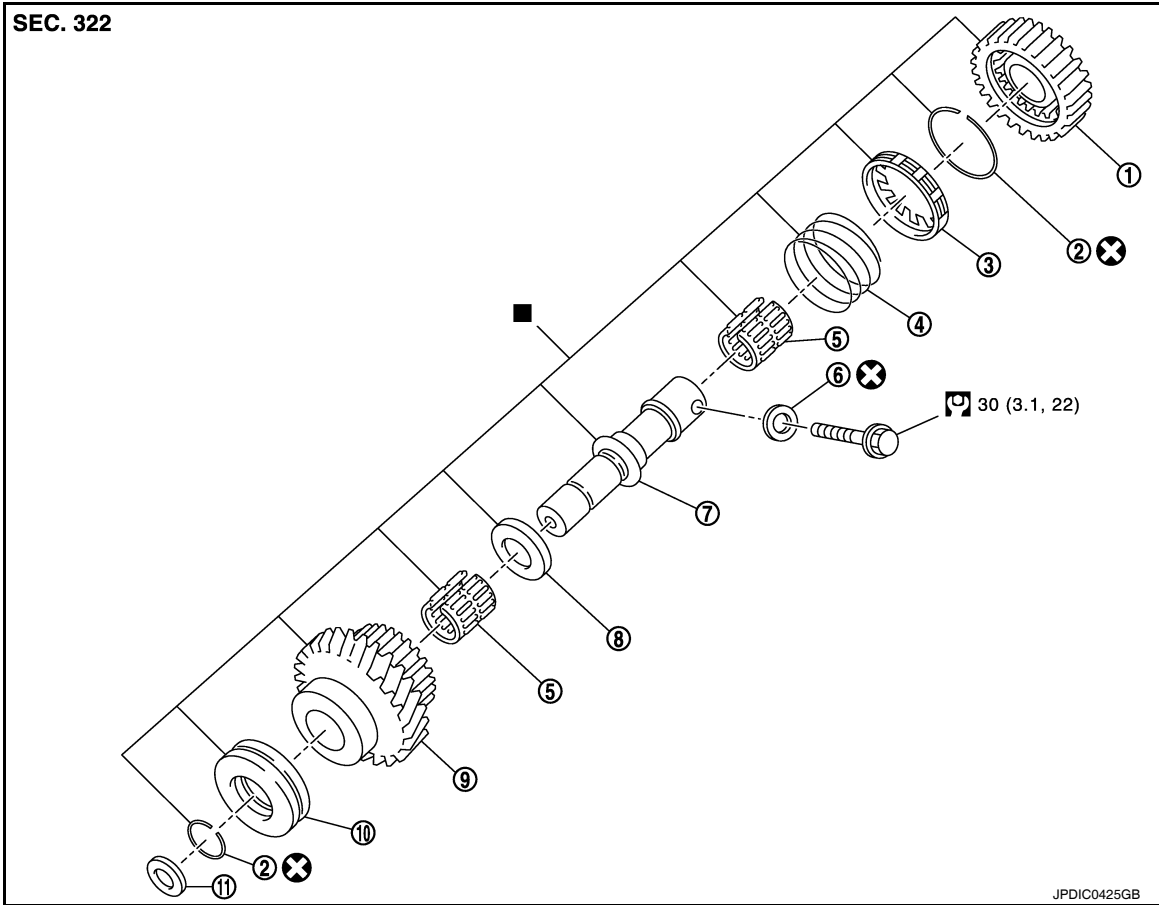

- | | | |
|------------------------|-------------------|-----------------------|
| 1. Reverse output gear | 2. Snap ring | 3. Reverse baulk ring |
| 4. Return spring | 5. Needle bearing | 6. Seal washer |
| 7. Reverse idler shaft | 8. Spacer | 9. Reverse input gear |
| 10. Lock washer | 11. Spring washer | |

■: Replace the parts as a set.

Shift Control Components

A
B
MT
D
E
F
G
H
I
J
K
L
M
N
O
P

TRANSAXLE ASSEMBLY

< SERVICE INFORMATION >

[RS6F94R]

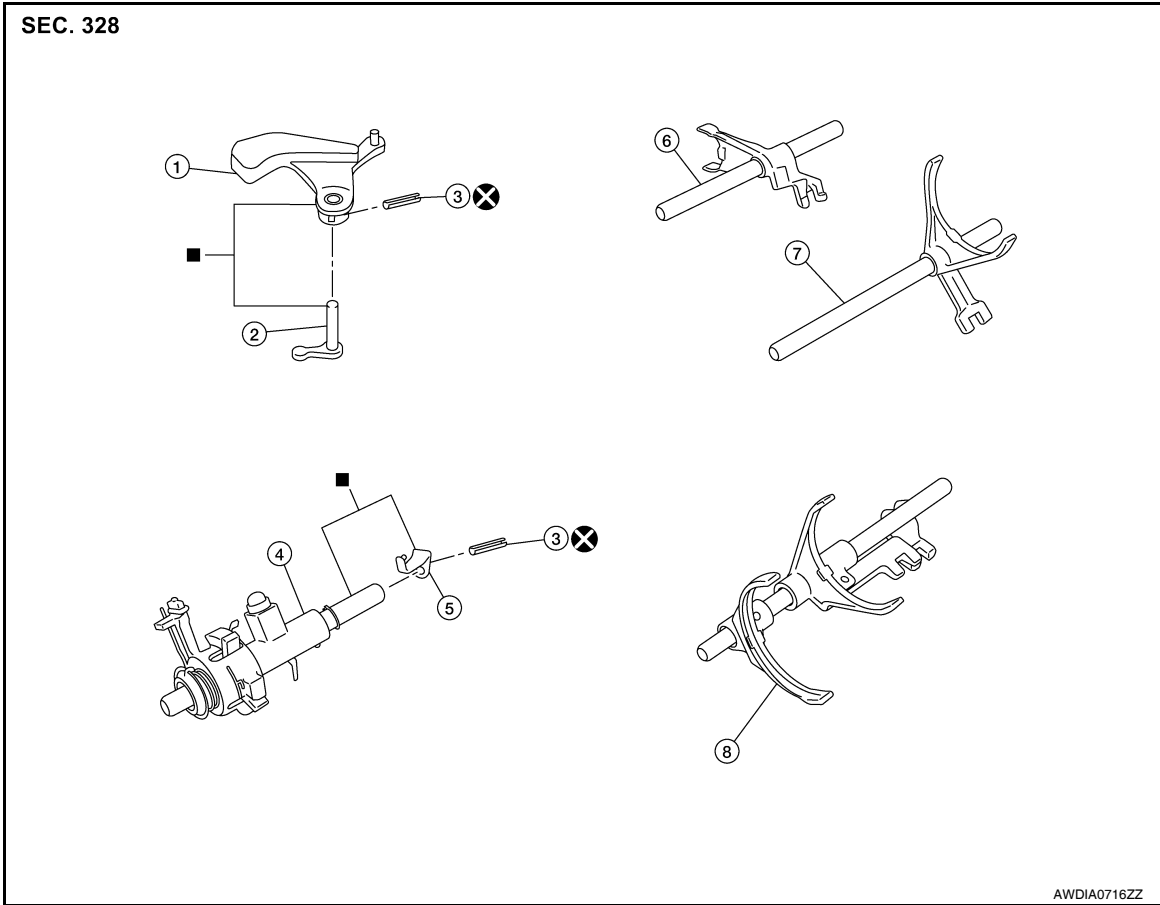

- | | | |
|---------------------|--------------------|---------------------|
| 1. Shifter lever A | 2. Shifter lever B | 3. Retaining pin |
| 4. Selector | 5. Selector lever | 6. Reverse fork rod |
| 7. 1st-2nd fork rod | 8. Fork rod | |

■: Replace the parts as a set.

Final Drive Components

TRANSAXLE ASSEMBLY

< SERVICE INFORMATION >

[RS6F94R]

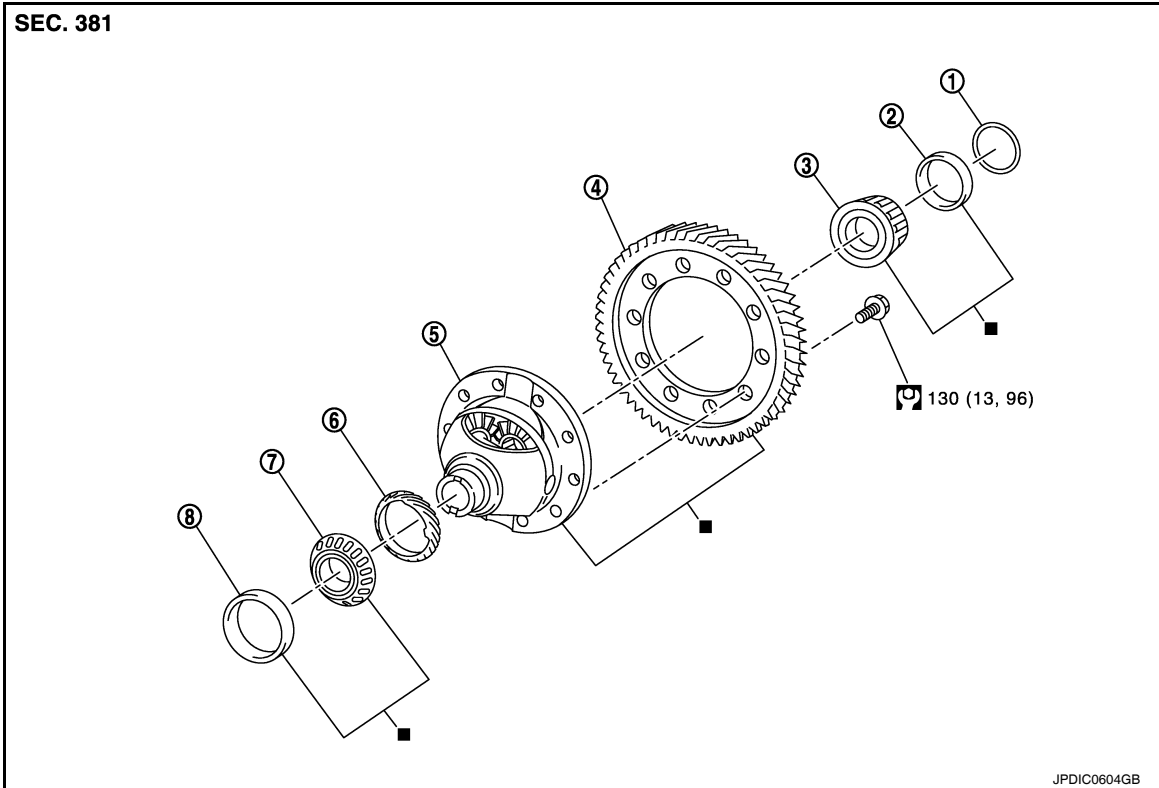

- | | | |
|---|---|---|
| 1. Shim | 2. Differential side bearing outer race (transaxle case side) | 3. Differential side bearing inner race (transaxle case side) |
| 4. Final gear | 5. Differential case | 6. Speedometer drive gear |
| 7. Differential side bearing inner race (clutch housing side) | 8. Differential side bearing outer race (clutch housing side) | |

■: Replace the parts as a set.

DISASSEMBLY

1. Remove drain plug and gasket from clutch housing, using a suitable tool and then drain gear oil.
2. Remove filler plug and gasket from transaxle case.
3. Remove selector lever (1) retaining pin with a pin punch to remove selector lever.
4. Remove bracket (2) and position switch (3) from transaxle case.

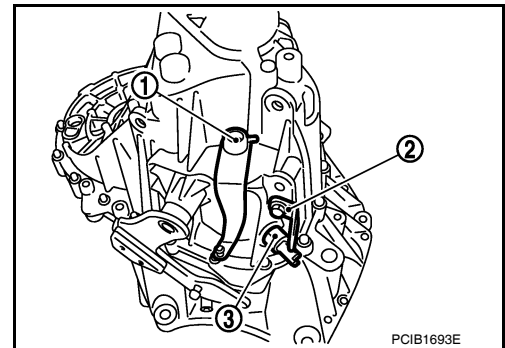

A
B
MT
D
E
F
G
H
I
J
K
L
M
N
O
P

TRANSAXLE ASSEMBLY

[RS6F94R]

< SERVICE INFORMATION >

5. Remove transaxle case bolts (←).

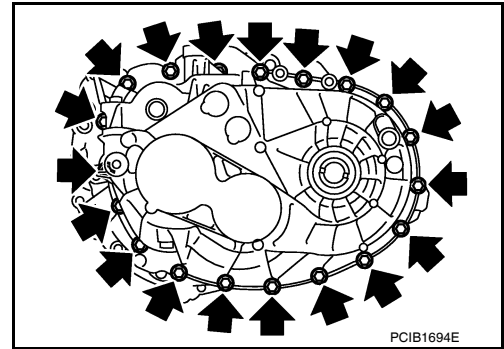

6. Remove reverse idler shaft bolt (←) and seal washer.

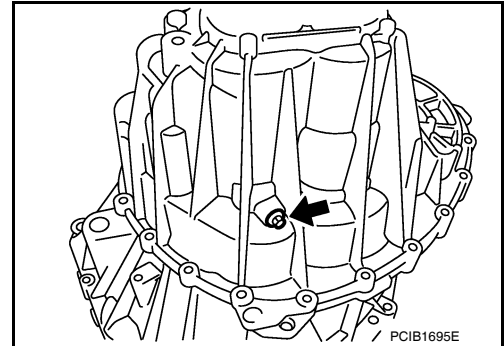

7. Remove transaxle case (2) while rotating shifter lever A (1) in the direction as shown.

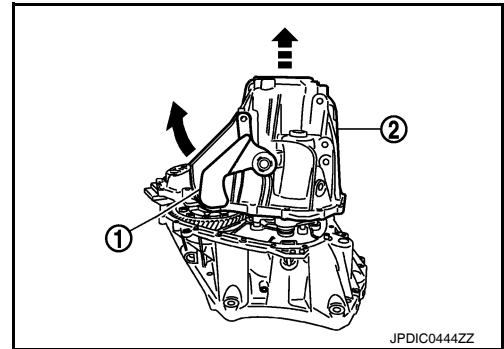

8. Remove selector spring (1) from return bushing (A).

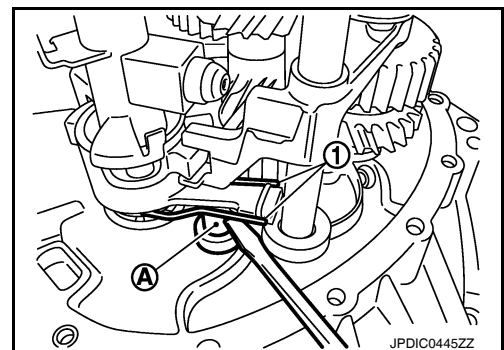

9. Shift 1st-2nd fork rod (1), fork rod (2), and reverse fork rod (3) to the neutral position.

10. Remove selector (4) from clutch housing.

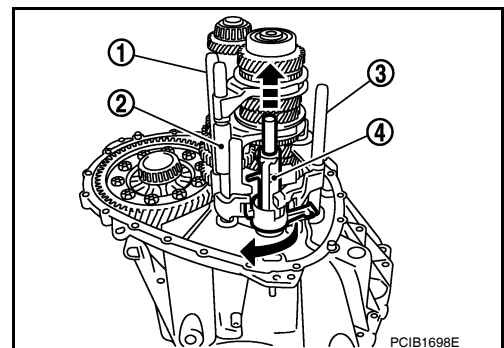

TRANSAXLE ASSEMBLY

[RS6F94R]

< SERVICE INFORMATION >

11. Remove reverse idler shaft assembly (1) according to the following procedures.

- a. Pull up input shaft assembly (2), mainshaft assembly (3), fork rod (4), and 1st-2nd fork rod (5).

NOTE:

It is easier to pull up when shifting each fork rod to each shaft side.

- b. Remove reverse idler shaft assembly and reverse fork rod (6) from clutch housing.

12. Remove spring washer from clutch housing.

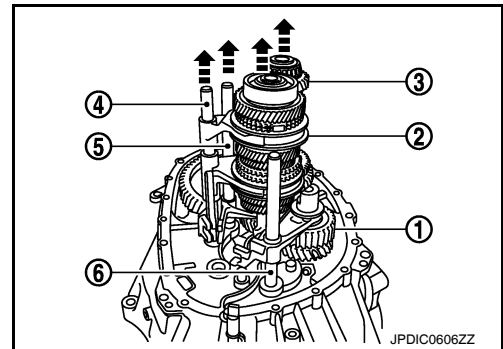

13. Pull up and remove input shaft assembly (1), mainshaft assembly (2), fork rod (3), and 1st-2nd fork rod (4) from clutch housing.

NOTE:

It is easier to pull up when shifting each fork rod to each shaft side.

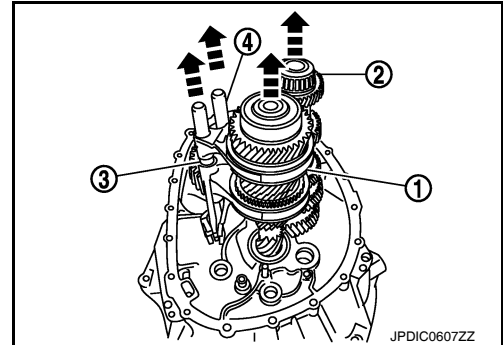

14. Remove final drive assembly (1) from clutch housing.

15. Remove magnet from clutch housing.

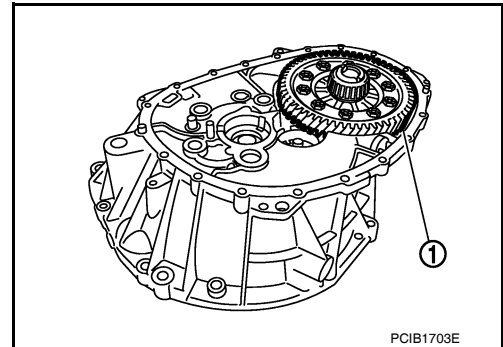

16. Remove differential side oil seals (1) from clutch housing and transaxle case.

CAUTION:

- Do not damage clutch housing and transaxle case.
- Do not reuse differential side oil seals.

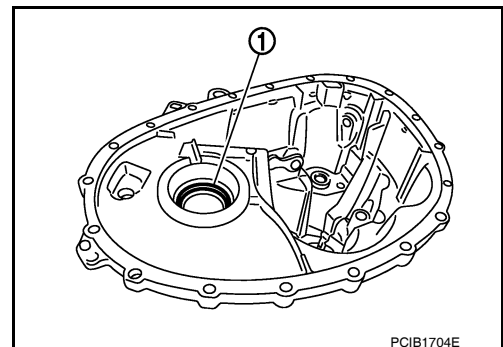

17. Remove differential side bearing outer race (1) from clutch housing, using a brass rod.

CAUTION:

Do not damage clutch housing.

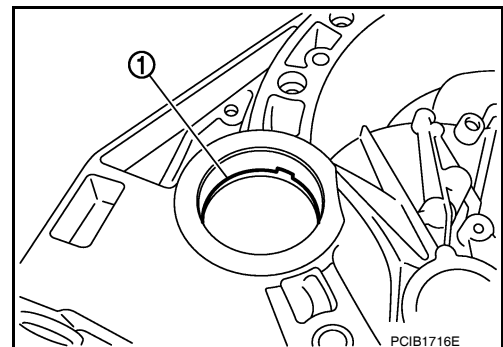

A

B

MT

D

E

F

G

H

I

J

K

L

M

N

O

P

TRANSAXLE ASSEMBLY

[RS6F94R]

< SERVICE INFORMATION >

18. Remove differential side bearing outer race (1) from transaxle case, using a brass rod.

CAUTION:

Do not damage transaxle case.

19. Remove shim (2) from transaxle case.

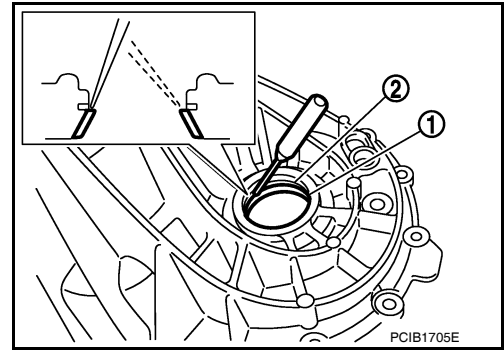

20. Remove shifter lever A (1) retaining pin, using a suitable tool.

21. Remove shifter lever A from transaxle case.

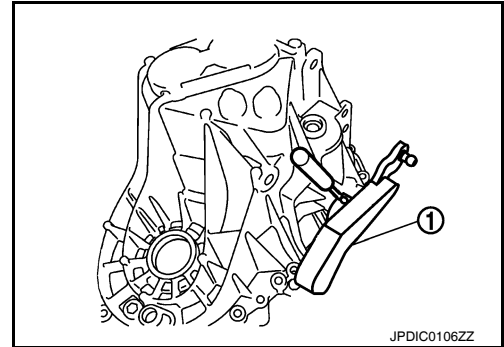

22. Remove shifter lever B (1) from transaxle case.

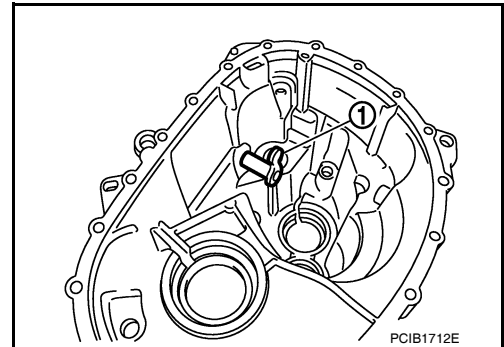

23. Remove oil gutter (1) from transaxle case.

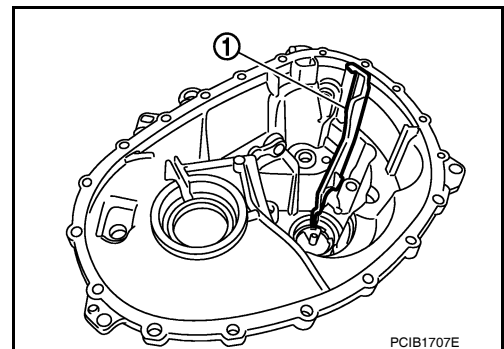

24. Remove bushings (1) from transaxle case, using a suitable tool.

CAUTION:

Do not reuse bushings.

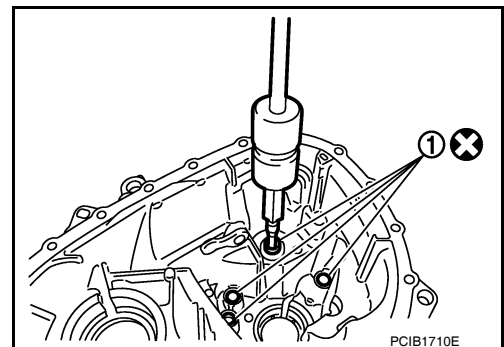

TRANSAXLE ASSEMBLY

[RS6F94R]

< SERVICE INFORMATION >

25. Remove mainshaft rear bearing outer race from transaxle case, using a suitable tool.
26. Remove mainshaft rear bearing adjusting shim from transaxle case.

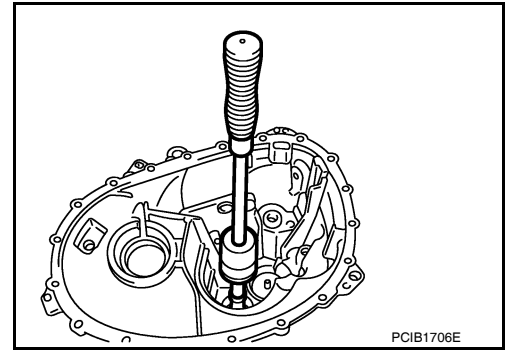

27. Remove snap ring (1) and oil channel (2) from transaxle case.

CAUTION:

Do not reuse snap ring and oil channel.

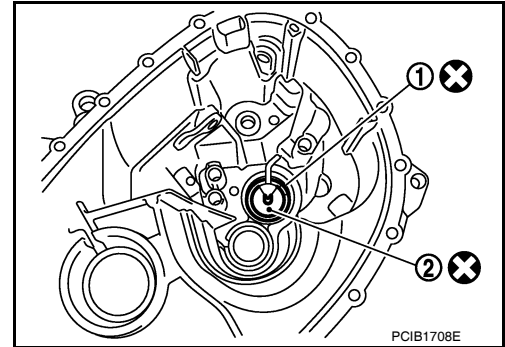

28. Remove input shaft oil seal (1) from clutch housing, using a suitable tool.

CAUTION:

- Do not damage clutch housing.
- Do not reuse input shaft oil seal.

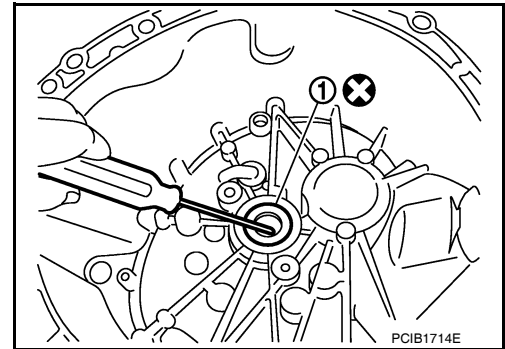

29. Remove mainshaft front bearing outer race (1) from clutch housing, using Tool (A) and a suitable tool (B).

Tool number : KV381054S0 (J-34286)

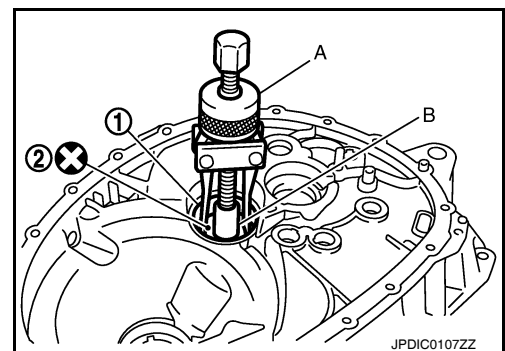

30. Remove oil channel (2) from clutch housing.

A
B
MT
D
E
F
G
H
I
J
K
L
M
N
O
P

TRANSAXLE ASSEMBLY

[RS6F94R]

< SERVICE INFORMATION >

31. Remove bushing (1) from clutch housing, using suitable tool.

CAUTION:

Do not reuse bushing.

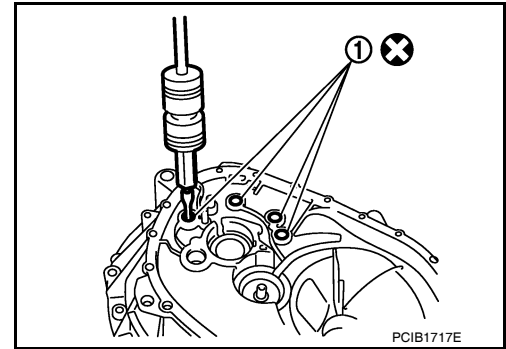

32. Remove two way connector (1) from clutch housing.

33. Remove plug from clutch housing.

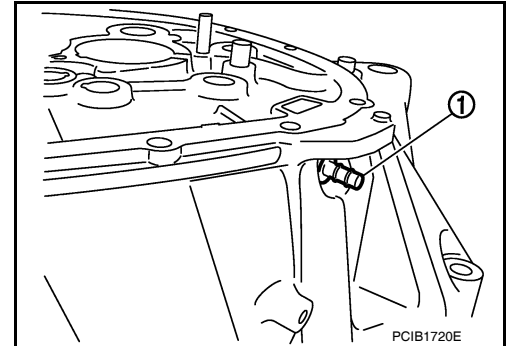

34. Remove pinion gear (1) and pinion shaft (2) from clutch housing.

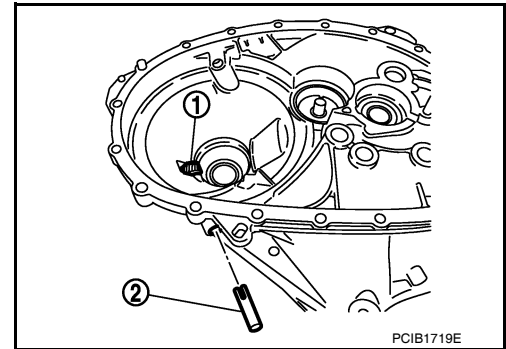

ASSEMBLY

1. Install pinion gear (1) and pinion shaft (2) to clutch housing.

CAUTION:

Replace transaxle assembly when replacing clutch housing.

2. Install plug to clutch housing.

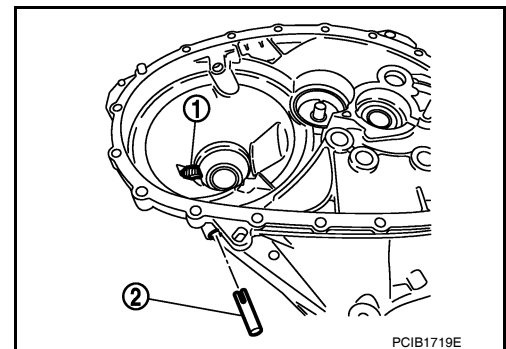

TRANSAXLE ASSEMBLY

[RS6F94R]

< SERVICE INFORMATION >

3. Install two way connector (1) to clutch housing.

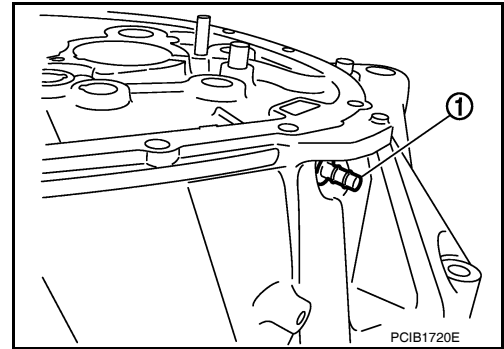

4. Install bushings (1) so that they become even to clutch housing edge surface, using a suitable tool (A).

CAUTION:

Do not reuse bushings.

5. Install oil channel to clutch housing.

CAUTION:

Do not reuse oil channel.

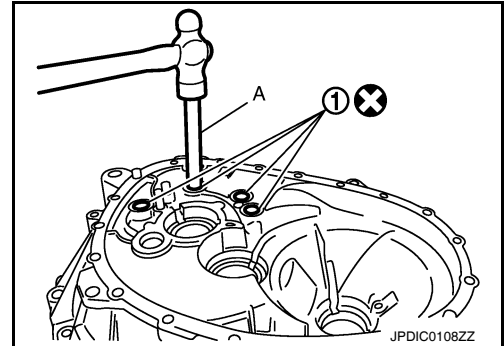

6. Install mainshaft front bearing outer race to clutch housing, using Tool (A).

Tool number : KV38100200 (—)

CAUTION:

Replace mainshaft front bearing outer race and mainshaft front bearing inner race as a set.

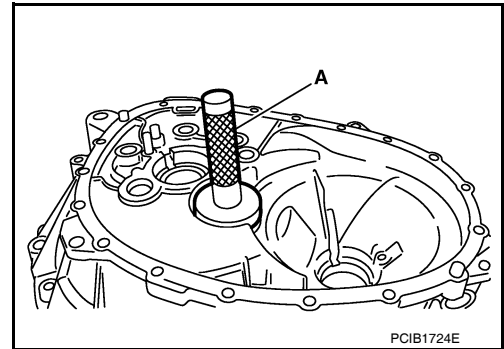

7. Install input shaft oil seal (1) to clutch housing, using Tool (A).

CAUTION:

Do not reuse input shaft oil seal.

Tool number : ST33220000 (—)

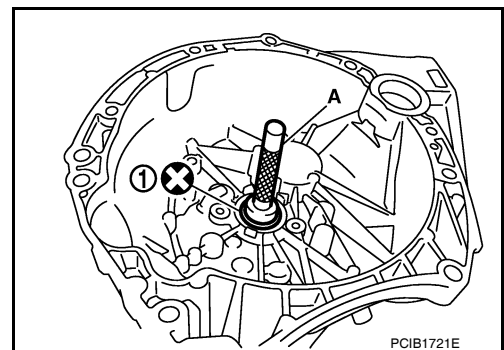

8. Install snap ring (1) and oil channel (2) to transaxle case.

CAUTION:

- Do not reuse snap ring and oil channel.
- Select and install snap ring that has the same thickness as previous one.
- Replace transaxle assembly when replacing transaxle case.

9. Install mainshaft rear bearing adjusting shim to transaxle case.

CAUTION:

Select mainshaft rear bearing adjusting shim according to the following procedures when replacing mainshaft adjusting shim, 6th main gear, 5th main gear, or 4th main gear.

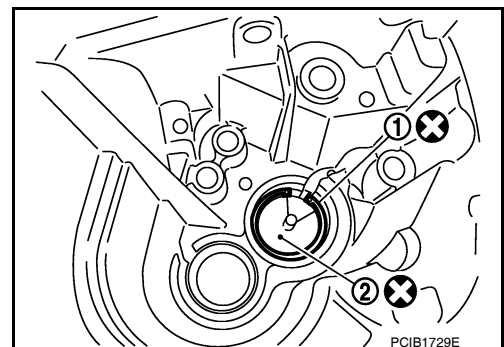

A
B
MT
D
E
F
G
H
I
J
K
L
M
N
O
P

TRANSAXLE ASSEMBLY

[RS6F94R]

< SERVICE INFORMATION >

- Do not reuse mainshaft adjusting shim.
- If new mainshaft adjusting shim is thinner than previous one, offset the thickness difference by selecting thicker mainshaft rear bearing adjusting shim.
- If new mainshaft adjusting shim is thicker than previous one, offset the thickness difference by selecting thinner mainshaft rear bearing adjusting shim.
- Replace 6th main gear, 5th main gear, or 4th main gear.
- Measure the thickness of the main gear used before and the new main gear
- Increase the thickness of the mainshaft rear bearing adjusting shim, if the difference is smaller than 0.025 mm (0.0010 in).
- Decrease the thickness of the mainshaft rear bearing adjusting shim, if the difference is greater than 0.025 mm (0.0010 in).

10. Install mainshaft rear bearing outer race to transaxle case, using Tool (A).

Tool number : KV38100200 (—)

CAUTION:

Replace mainshaft rear bearing outer race and mainshaft rear bearing inner race as a set.

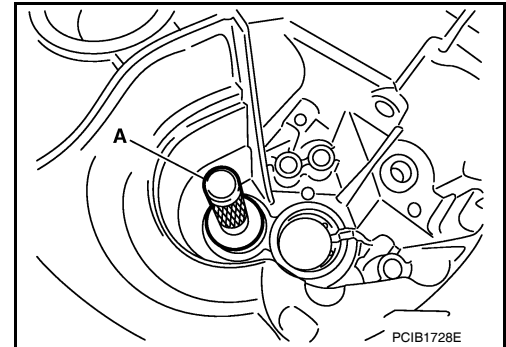

11. Install bushings (1) to transaxle case, using suitable (A).

CAUTION:

Do not reuse bushings.

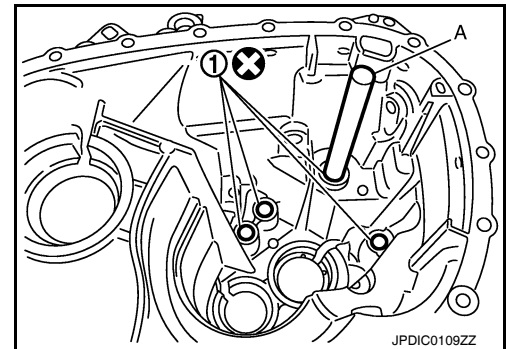

12. Install oil gutter (1) to transaxle case.

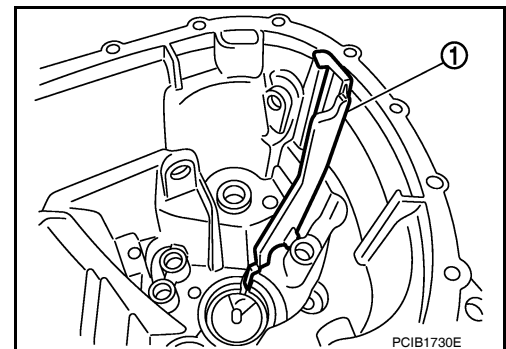

13. Install shifter lever B (1) to transaxle case.

CAUTION:

Replace shifter lever A and shifter lever B as a set.

14. Install shifter lever A to transaxle case.

CAUTION:

Replace shifter lever A and shifter lever B as a set.

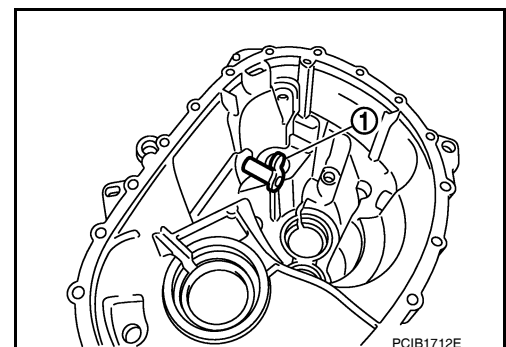

TRANSAXLE ASSEMBLY

[RS6F94R]

< SERVICE INFORMATION >

15. Install retaining pin to shifter lever A (1), using a pin punch.

CAUTION:

Do not reuse retaining pin.

16. Install shim to transaxle case.

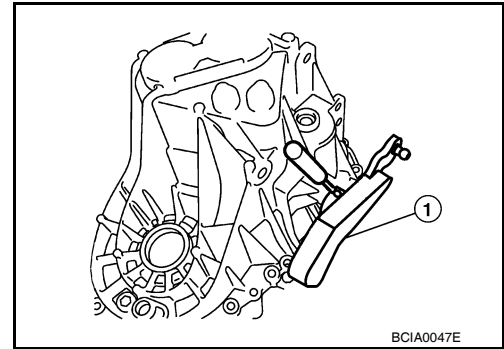

17. Install differential side bearing outer race (transaxle case side) to transaxle case, using Tool (A).

Tool number : ST33400001 (J-26082)

CAUTION:

Replace differential side bearing outer race (transaxle case side) and differential side bearing inner race (transaxle case side) as a set.

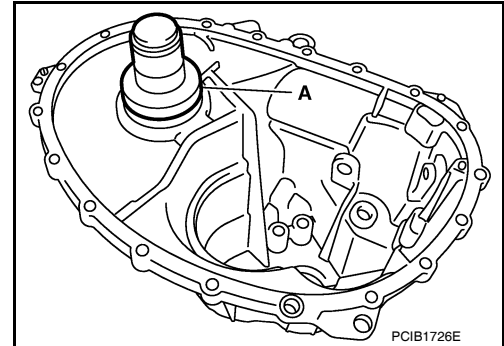

18. Install differential side bearing outer race (clutch housing side) to clutch housing, using Tool (A).

Tool number : KV38100200 (—)

CAUTION:

Replace differential side bearing outer race (clutch housing side) and differential side bearing inner race (clutch housing side) as a set.

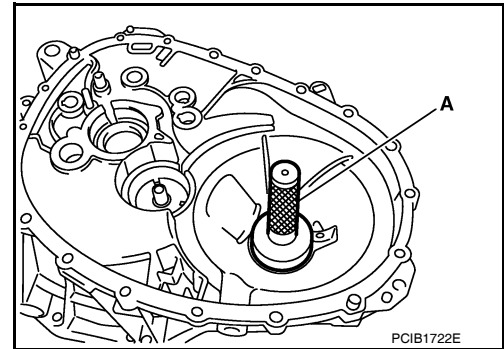

19. Install differential side oil seals (1) to clutch housing and transaxle case, using Tool.

Tool number : KV32500QAA (B.vi 1666-B)

(A) : Transaxle case side

(B) : Clutch housing side

Dimension (L1) : 1.2 – 1.8 mm (0.047 – 0.071 in)

Dimension (L2) : 2.7 – 3.3 mm (0.106 – 0.130 in)

CAUTION:

- Do not reuse differential side oil seal.
- Do not incline differential side oil seal.
- Do not damage clutch housing and transaxle case.

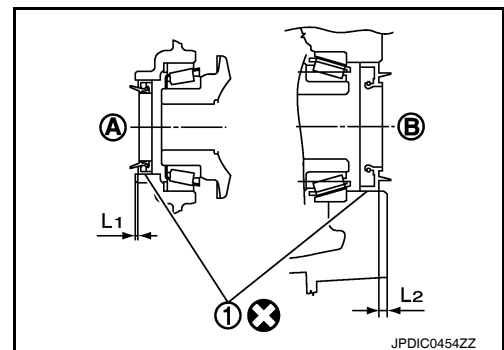

20. Install magnet to clutch housing.

21. Install final drive assembly to clutch housing.

TRANSAXLE ASSEMBLY

[RS6F94R]

< SERVICE INFORMATION >

22. Set fork rod (1) to input shaft assembly (2), and then install them to clutch housing.

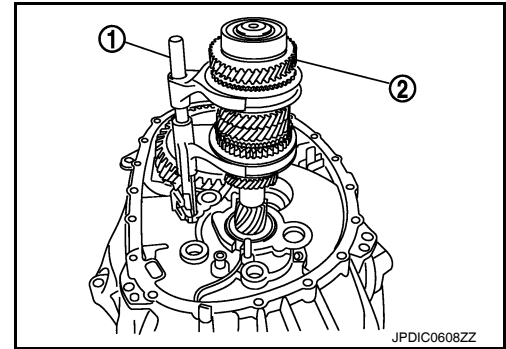

23. Install mainshaft assembly (1) according to the following procedures.
- Pull up input shaft assembly (2) and fork rod (3).
 - Set 1st-2nd fork rod (4) to mainshaft assembly, and then install them to clutch housing.

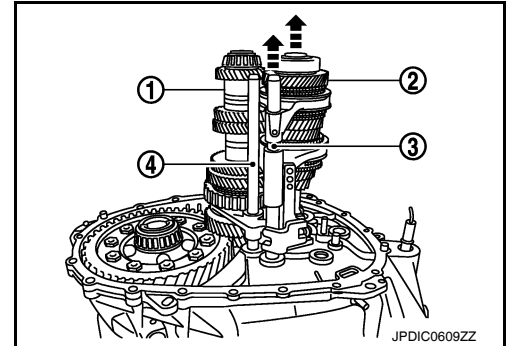

24. Install reverse idler shaft assembly (1) according to the following procedures.
- Install spring washer to clutch housing.
 - Pull up input shaft assembly (2), mainshaft assembly (3), fork rod (4), and 1st-2nd fork rod (5).

NOTE:

It is easier to pull up when shifting each fork rod to each shaft side.

- Set reverse fork rod (6) to reverse idler shaft assembly, and then install them to clutch housing.

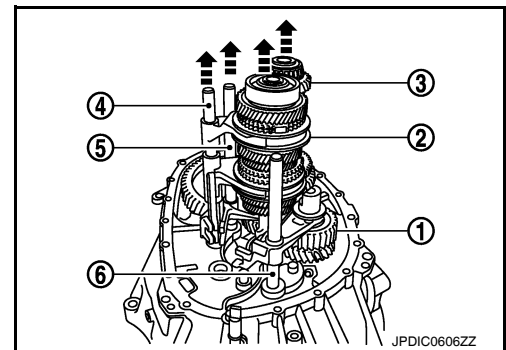

25. Shift 1st-2nd fork rod (1), fork rod (2), and reverse fork rod (3) to the neutral position.
26. Install selector (4) to clutch housing.

CAUTION:

Replace selector lever and selector as a set.

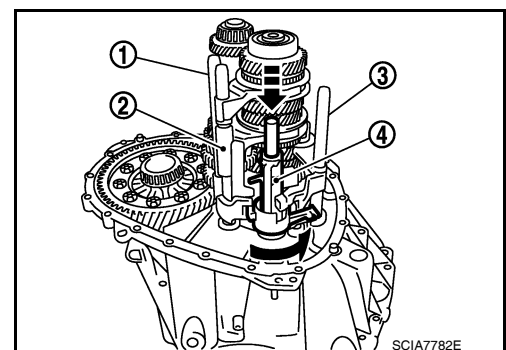

27. Install selector spring (1) to return bushing (A).
28. Apply recommended sealant to transaxle case mounting surface.

- Use Genuine Liquid Gasket, Three Bond 1215 or an equivalent.

CAUTION:

- Do not allow old liquid gasket, moisture, oil, or foreign matter to remain on mounting surface.
- Check that mounting surface is not damaged.
- Apply liquid gasket bead continuously.

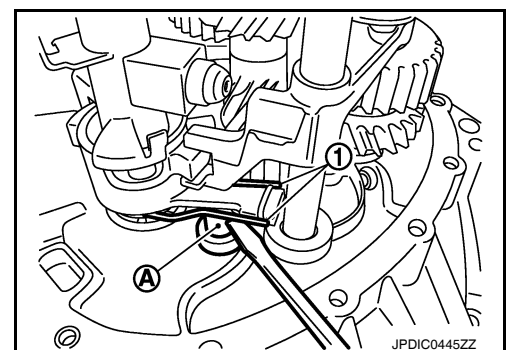

TRANSAXLE ASSEMBLY

[RS6F94R]

< SERVICE INFORMATION >

29. Install transaxle case to clutch housing while rotating shifter lever A (1) in the direction as shown.

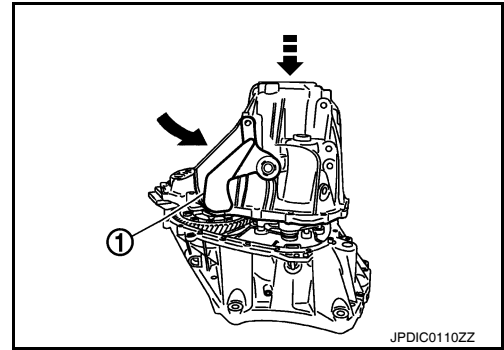

30. Install reverse idler shaft bolt (←) according to the following procedures.

- a. Install seal washer to reverse idler shaft bolt, and install reverse idler shaft bolt to transaxle case.

CAUTION:

Do not reuse seal washer.

- b. Tighten reverse idler shaft bolt to the specified torque. Refer to [MT-19, "Disassembly and Assembly"](#).

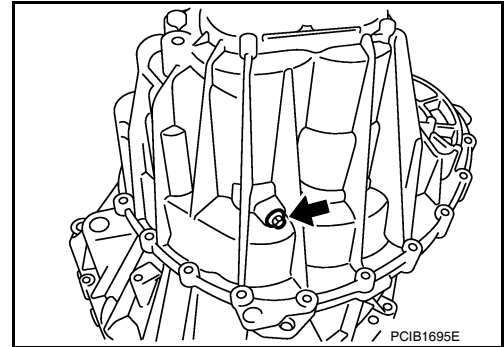

31. Tighten transaxle case bolts (←) to the specified torque. Refer to [MT-19, "Disassembly and Assembly"](#).

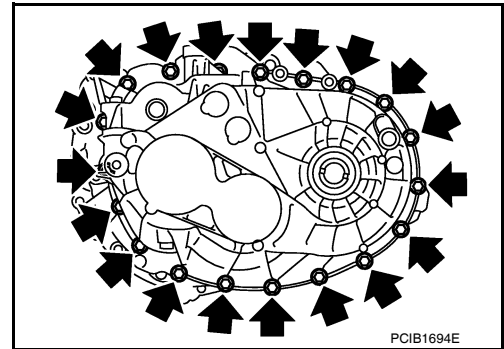

32. Install position switch (1) according to the following procedures.

- a. Apply recommended sealant to position switch thread.
• Use Genuine Liquid Gasket, Three Bond 1215 or an equivalent.

CAUTION:

Do not allow old liquid gasket, moisture, oil, or foreign matter to remain on thread.

- b. Install position switch to transaxle case, and tighten it to the specified torque. Refer to [MT-19, "Disassembly and Assembly"](#).

33. Install bracket (2) to transaxle case, and tighten bolt to the specified torque. Refer to [MT-19, "Disassembly and Assembly"](#).

34. Install selector lever (3) according to following the procedures.

- a. Install selector lever to transaxle case.

CAUTION:

Replace selector lever and selector as a set.

- b. Install retaining pin to selector lever, using a suitable tool.

CAUTION:

Do not reuse retaining pin.

35. Install drain plug according to the following procedures.

- a. Install gasket to drain plug.

CAUTION:

Do not reuse gasket.

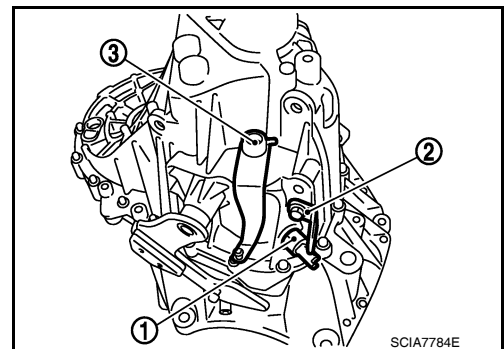

A
B
MT
D
E
F
G
H
I
J
K
L
M
N
O
P

TRANSAXLE ASSEMBLY

[RS6F94R]

< SERVICE INFORMATION >

- b. Install drain plug to clutch housing, using a suitable tool.
 - c. Tighten drain plug to the specified torque. Refer to [MT-19, "Disassembly and Assembly"](#).
36. Install filler plug according to the following procedures.
- a. Install gasket to filler plug, and then install filler plug to transaxle case.
CAUTION:
Do not reuse gasket.
 - b. Tighten filler plug to the specified torque. Refer to [MT-19, "Disassembly and Assembly"](#).
CAUTION:
Fill with gear oil before tightening filler plug to the specified torque.

INPUT SHAFT AND GEARS

Disassembly and Assembly

INFOID:000000007330305

GENERAL PRECAUTIONS

- Do not reuse snap ring.
- Secure input shaft in a vise with backplate, and then remove gears and snap rings.
- For installation and removal of snap ring, set snap ring pliers and flat pliers at both sides of snap ring. While expanding snap ring with snap ring pliers, move snap ring with flat pliers.
- Disassemble gear components putting direction marks on the parts that do not affect any functions.

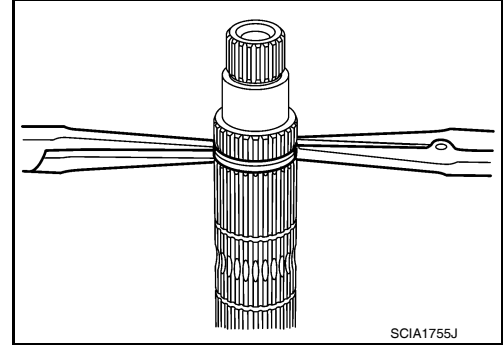

DISASSEMBLY

1. Remove input shaft rear bearing bolt (1) using Tool (A).

CAUTION:

Do not reuse input shaft rear bearing bolt.

Tool number (A): KV32300QAM (—)

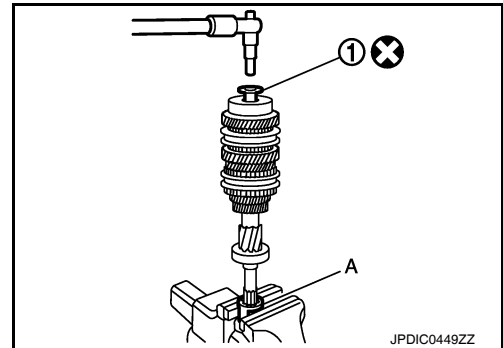

2. Remove input shaft rear bearing (1) according to the following procedures.
 - a. Set a suitable puller to input shaft rear bearing.
 - b. Remove input shaft rear bearing using a suitable drift (A).

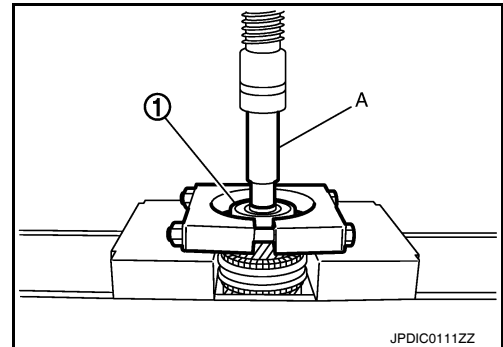

3. Remove spacer (1), 6th input gear (2), needle bearing, 6th baulk ring, and 5th-6th synchronizer hub assembly (3).
4. Remove insert keys and 5th-6th coupling sleeve from 5th-6th synchronizer hub.

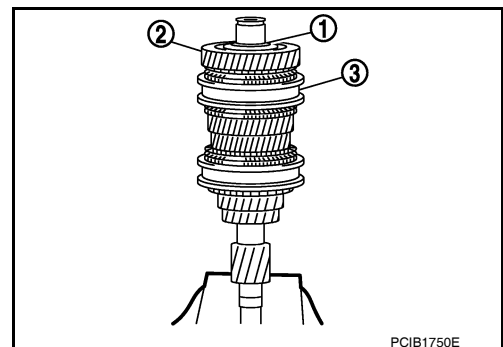

A
B
MT
D
E
F
G
H
I
J
K
L
M
N
O
P

INPUT SHAFT AND GEARS

[RS6F94R]

< SERVICE INFORMATION >

5. Remove snap ring (1) using suitable tool.

CAUTION:

Do not reuse snap ring.

6. Remove spacer, 5th baulk ring, 5th input gear (2), and spacer.

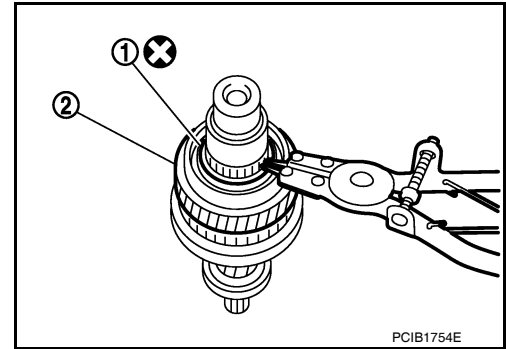

7. Remove snap ring (1) using suitable tool.

CAUTION:

Do not reuse snap ring.

8. Remove spacer, 4th input gear (2), 4th baulk ring, and 3rd-4th synchronizer hub assembly (3).

9. Remove insert keys and 3rd-4th coupling sleeve from 3rd-4th synchronizer hub.

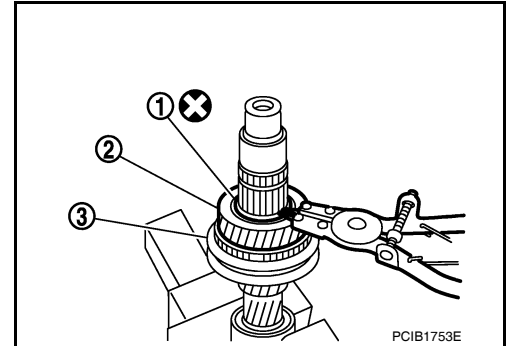

10. Remove snap ring (1).

CAUTION:

Do not reuse snap ring.

11. Remove spacer, 3rd baulk ring, 3rd input gear (2).

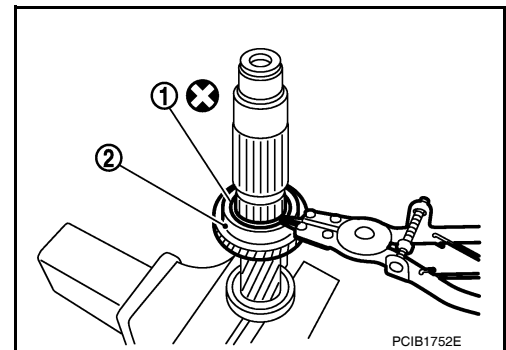

12. Set a suitable puller to input shaft front bearing (1), and then remove input shaft front bearing.

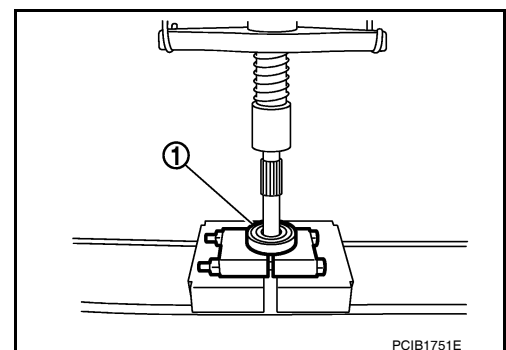

INSPECTION AFTER DISASSEMBLY

Input shaft and gear

Check the following items and replace if necessary.

INPUT SHAFT AND GEARS

[RS6F94R]

< SERVICE INFORMATION >

- Damage, peeling, bend, uneven wear, and distortion of shaft.
- Excessive wear, damage, and peeling of gear.

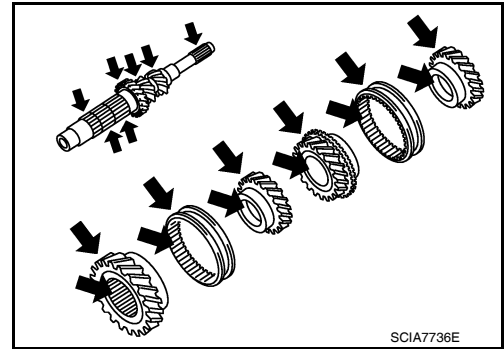

Synchronizer

- Synchronizer hub and coupling sleeve
Check the following items and replace if necessary.
- Breakage, damage, and unusual wear on contact surface of coupling sleeve, synchronizer hub, and insert key.
- Coupling sleeve and synchronizer hub move smoothly.

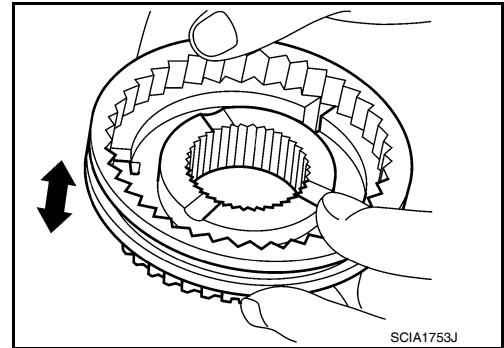

Baulk ring

- Baulk ring
Check contact surface of baulk ring cam and insert key for excessive wear, uneven wear, bend, and damage. Replace if necessary.

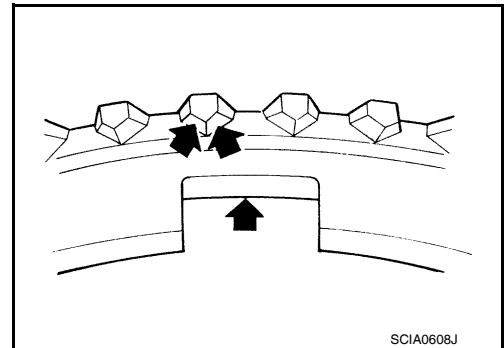

Bearing

- Bearing
Check bearing for damage and rough rotation. Replace if necessary.

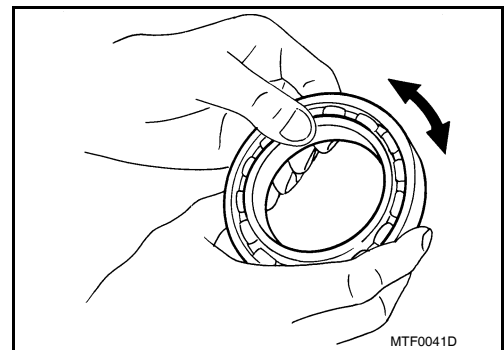

ASSEMBLY

Note the following procedures, and assemble in the reverse order of disassembly.

CAUTION:

- Replace transaxle assembly when replacing input shaft.
- Do not reuse snap ring.
- Check that snap ring is securely installed in a groove.
- Replace 3rd-4th coupling sleeve and 3rd-4th synchronizer hub as a set.

A
B
MT
D
E
F
G
H
I
J
K
L
M
N
O
P

INPUT SHAFT AND GEARS

[RS6F94R]

< SERVICE INFORMATION >

- Replace 5th-6th coupling sleeve and 5th-6th synchronizer hub as a set.
- Be careful to install 3rd-4th synchronizer hub according to the specified direction.

(A) : 3rd input gear side

(B) : 4th input gear side

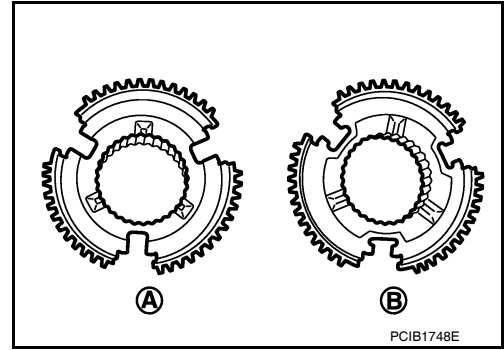

- Be careful to install 5th-6th synchronizer hub according to the specified direction.

(A) : 5th input gear side

(B) : 6th input gear side

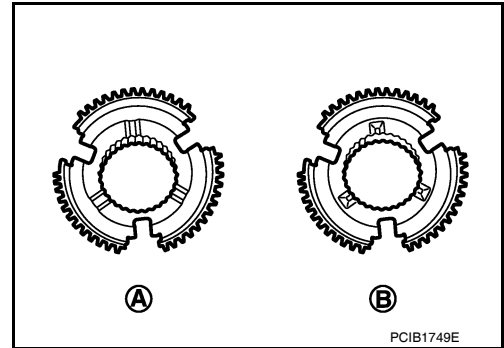

- Install input shaft front bearing (1) using a suitable drift (A).

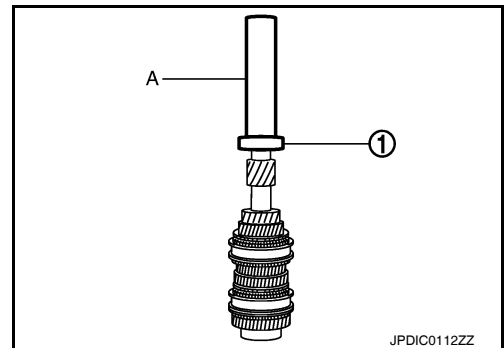

- Install input shaft rear bearing (1) using a suitable drift (A) and the Tool (B).

Tool number (B): ST36720030 (—)

- Apply gear oil to 3rd baulk ring, 4th baulk ring, 5th baulk ring, and 6th baulk ring.

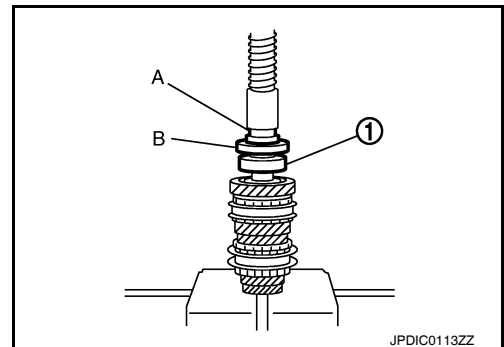

INPUT SHAFT AND GEARS

[RS6F94R]

< SERVICE INFORMATION >

- Install input shaft rear bearing bolt (1) according to the following procedures.

CAUTION:

- Do not reuse input shaft rear bearing bolt.
 - Follow the procedures. Otherwise it may cause a transaxle malfunction.
1. Secure the Tool (A) in a vise, and then set input shaft assembly.

Tool number (A): KV32300QAM (—)
 2. Install input shaft rear bearing bolt, and then tighten it to the specified torque of the 1st step. Refer to [MT-19, "Disassembly and Assembly"](#).
 3. Loosen input shaft rear bearing bolt by a half turn.
 4. Tighten input shaft rear bearing bolt to the specified torque of the 2nd step. Refer to [MT-19, "Disassembly and Assembly"](#).

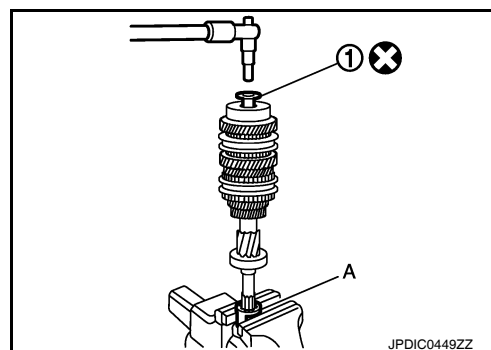

A
B
MT
D
E
F
G
H
I
J
K
L
M
N
O
P

MAINSHAFT AND GEARS

Disassembly and Assembly

INFOID:000000007330306

GENERAL PRECAUTIONS

- Do not reuse snap ring.
- Secure mainshaft in a vise with backplate, and then remove gears and snap rings.
- For installation and removal of snap ring, set snap ring pliers and flat pliers at both sides of snap ring. While expanding snap ring with snap ring pliers, move snap ring with flat pliers.
- Disassemble gear components putting direction marks on the parts that do not affect any functions.

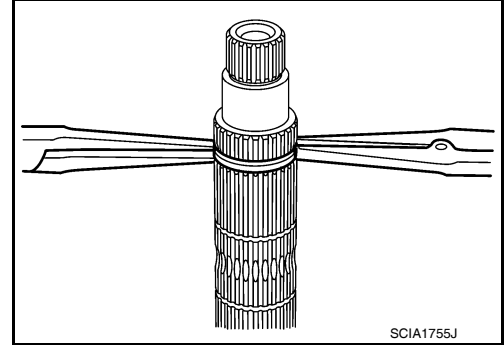

DISASSEMBLY

1. Remove snap ring (1) using suitable tool.

CAUTION:
Do not reuse snap ring.

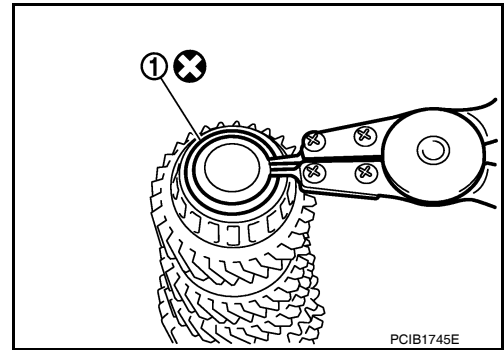

2. Remove 6th main gear (1) and mainshaft rear bearing inner race (2) according to the following procedures.
 - a. Set a suitable puller to 6th main gear.
 - b. Remove mainshaft rear bearing inner race and 6th main gear using the Tool (A).

Tool number (A): ST33052000 (—)

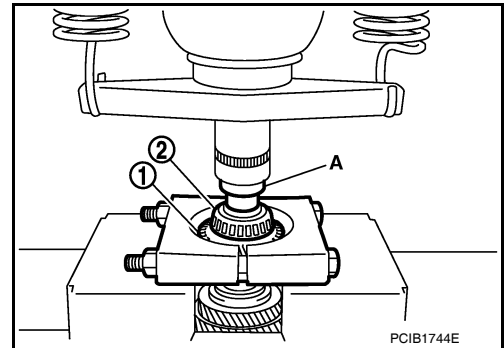

3. Remove 4th main gear (1) and 5th main gear (2) according to the following procedures.
 - a. Set a suitable tool to 4th main gear.
 - b. Remove 5th main gear and 4th main gear using Tool (A).

Tool number (A): ST33052000 (—)

4. Remove mainshaft adjusting shim.

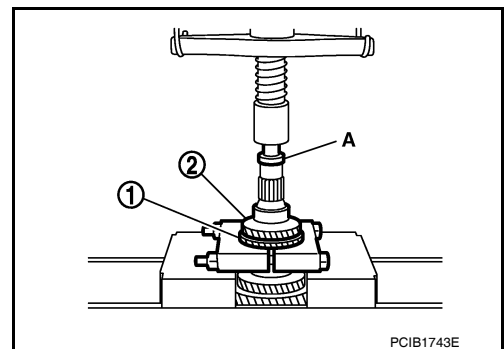

MAINSHAFT AND GEARS

[RS6F94R]

< SERVICE INFORMATION >

5. Remove 1st main gear (1), 1st-2nd synchronizer hub assembly (2), 2nd main gear (3), and 3rd main gear (4) according to the following procedures.
 - a. Set a suitable tool to 1st main gear.
 - b. Remove 3rd main gear, busing, 2nd main gear, 2nd inner baulk ring, 2nd synchronizer cone, 2nd outer baulk ring, 1st-2nd synchronizer hub assembly, 1st outer baulk ring, 1st synchronizer cone, 1st inner baulk ring, and 1st main gear using the Tool (A).

Tool number (A): ST33052000 (—)

- c. Remove insert keys and 1st-2nd coupling sleeve from 1st-2nd synchronizer hub.
6. Remove mainshaft front bearing inner race (1) according to the following procedures.
 - a. Set a suitable puller to mainshaft front bearing inner race.
 - b. Remove mainshaft front bearing inner race using the Tool (A).

Tool number (A): ST33052000 (—)

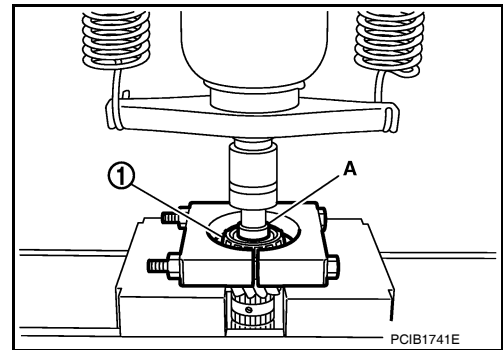
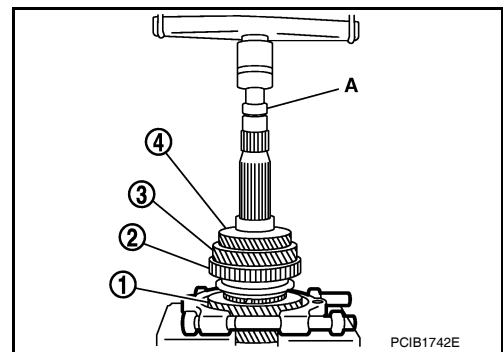

INSPECTION AFTER DISASSEMBLY

Mainshaft and Gear

Check the following items and replace if necessary.

- Damage, peeling, bend, uneven wear, and distortion of shaft.
- Excessive wear, damage, and peeling of gear.

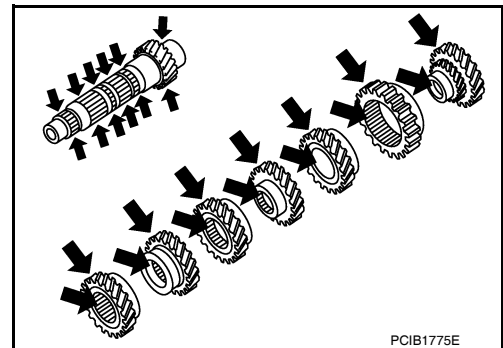

Synchronizer

- Synchronizer hub and coupling sleeve
Check the following items and replace if necessary.
 - Breakage, damage, and unusual wear on contact surface of coupling sleeve, synchronizer hub, and insert key.
 - Coupling sleeve and synchronizer hub move smoothly.

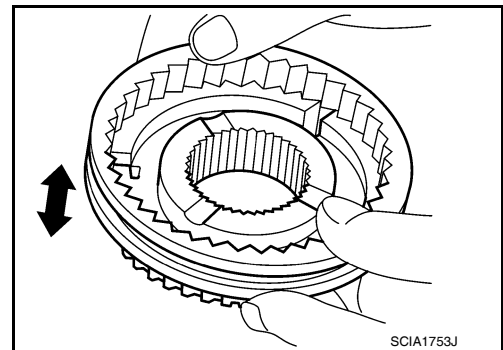

- Baulk ring

A
B
MT
D
E
F
G
H
I
J
K
L
M
N
O
P

MAINSHAFT AND GEARS

[RS6F94R]

< SERVICE INFORMATION >

Check contact surface of baulk ring cam and insert key for excessive wear, uneven wear, bend, and damage. Replace if necessary.

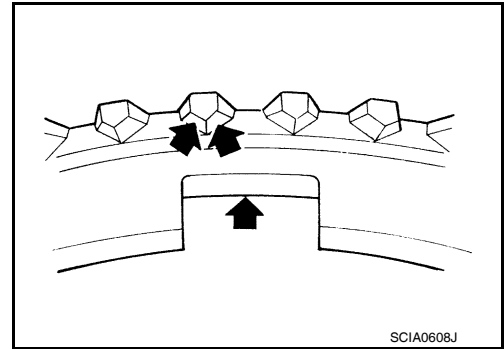

Bearing

Check bearing for damage and rough rotation. Replace if necessary.

CAUTION:

- Replace mainshaft front bearing outer race and mainshaft front bearing inner race as a set.
- Replace mainshaft rear bearing inner race and mainshaft rear bearing outer race as a set.

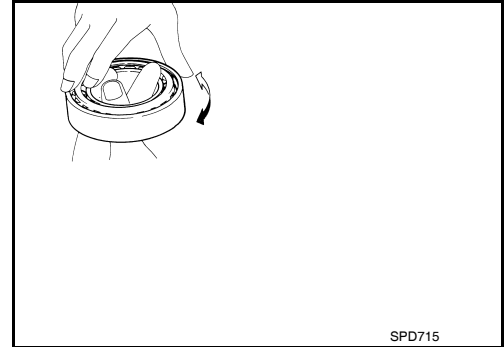

ASSEMBLY

CAUTION:

- Select mainshaft rear bearing adjusting shim according to the following procedures when replacing mainshaft adjusting shim, 6th main gear, 5th main gear, or 4th main gear.
- Do not reuse mainshaft adjusting shim.
- If new mainshaft adjusting shim is thinner than previous one, offset the thickness difference by selecting thicker mainshaft rear bearing adjusting shim.
- If new mainshaft adjusting shim is thicker than previous one, offset the thickness difference by selecting thinner mainshaft rear bearing adjusting shim.
- Replace 6th main gear, 5th main gear, or 4th main gear.
- Measure the thickness of the main gear used before and the new main gear
- Increase the thickness of the mainshaft rear bearing adjusting shim, if the difference is smaller than 0.025 mm (0.0010 in).
- Replace transaxle assembly when replacing mainshaft.

1. Install mainshaft front bearing inner race (1) using the Tool (A).

Tool number (A): ST36720030 (—)

CAUTION:

Replace mainshaft front bearing outer race and mainshaft front bearing inner race as a set.

2. Apply gear oil to 1st inner baulk ring, 1st synchronizer cone, 1st outer baulk ring, 2nd inner baulk ring, 2nd synchronizer cone, and 2nd outer baulk ring.

CAUTION:

- Replace 1st inner baulk ring, 1st synchronizer cone, and 1st outer baulk ring as a set.
- Replace 2nd inner baulk ring, 2nd synchronizer cone, and 2nd outer baulk ring as a set.

3. Install insert keys and 1st-2nd coupling sleeve to 1st-2nd synchronizer hub.

CAUTION:

Replace 1st-2nd synchronizer hub and 1st-2nd coupling sleeve as a set.

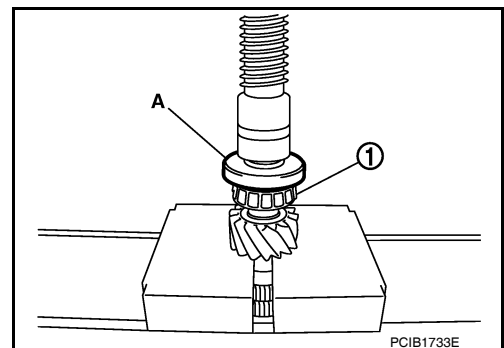

MAINSHAFT AND GEARS

[RS6F94R]

< SERVICE INFORMATION >

- Install 1st main gear (1), 1st inner baulk ring, 1st synchronizer cone, 1st outer baulk ring, 1st-2nd synchronizer hub assembly (2), 2nd inner baulk ring, 2nd synchronizer cone, and 2nd outer baulk ring.
- Install bushing (3) using the Tool (A).

Tool number (A): KV32102700 (—)

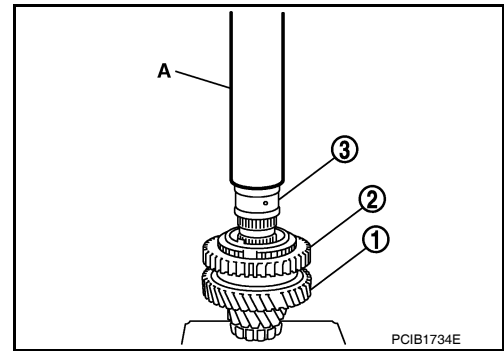

- Install 3rd main gear (1) and 2nd main gear (2) using Tool (A).

Tool number (A): ST32102700 (—)

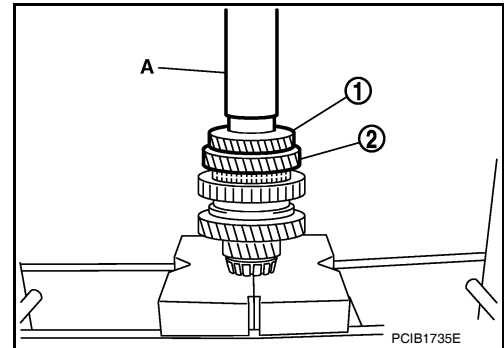

- Measure dimension (L) as shown. Select mainshaft adjusting shim (1) according to the following list, and then install it to mainshaft.

- 2 : Mainshaft
- 3 : 3rd main gear

Unit: mm (in)

Dimension (L)	Mainshaft adjusting shim thickness
147.690 – 147.666 (5.8146 – 5.8136)	1.500 (0.0591)
147.665 – 147.641 (5.8136 – 5.8126)	1.525 (0.0600)
147.640 – 147.616 (5.8126 – 5.8116)	1.550 (0.0610)
147.615 – 147.591 (5.8116 – 5.8107)	1.575 (0.0620)
147.590 – 147.566 (5.8106 – 5.8097)	1.600 (0.0630)
147.565 – 147.541 (5.8096 – 5.8087)	1.625 (0.0640)
147.540 – 147.516 (5.8086 – 5.8077)	1.650 (0.0650)
147.515 – 147.491 (5.8077 – 5.8067)	1.675 (0.0659)
147.490 – 147.466 (5.8067 – 5.8057)	1.700 (0.0669)
147.465 – 147.441 (5.8057 – 5.8048)	1.725 (0.0679)
147.440 – 147.416 (5.8047 – 5.8038)	1.750 (0.0689)
147.415 – 147.391 (5.8037 – 5.8028)	1.775 (0.0699)

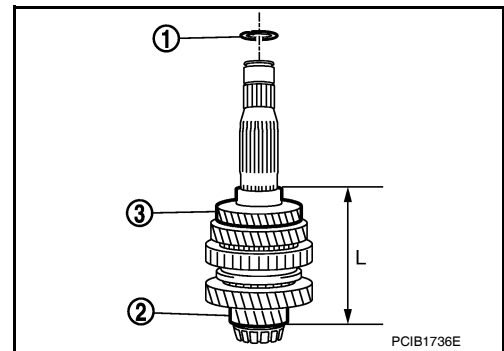

- Install 4th main gear (1) using Tool (A).

Tool number (A): KV32102700 (—)

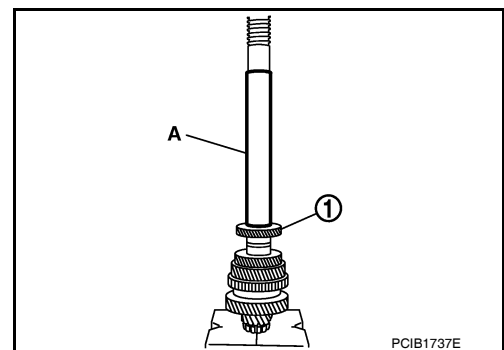

A
B
MT
D
E
F
G
H
I
J
K
L
M
N
O
P

MAINSHAFT AND GEARS

< SERVICE INFORMATION >

[RS6F94R]

9. Install 5th main gear (1) using Tool (A).

Tool number (A): KV32102700 (—)

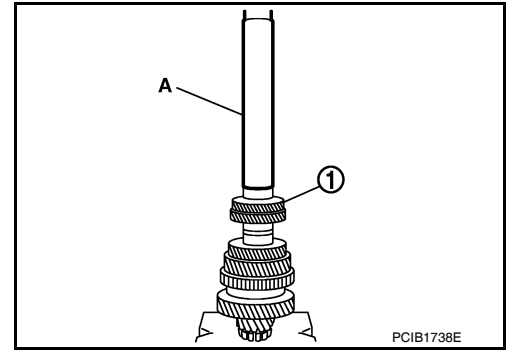

10. Install 6th main gear (1) using Tool (A).

Tool number (A): KV32102700 (—)

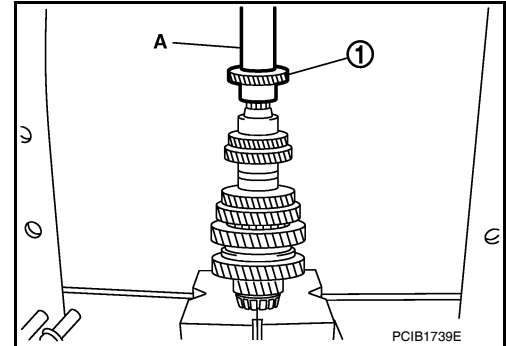

11. Install mainshaft rear bearing inner race (1) using Tool (A).

Tool number (A): ST30901000 (J-26010-01)

CAUTION:

Replace mainshaft rear bearing inner race and mainshaft rear bearing outer race as a set.

12. Install snap ring.

CAUTION:

Do not reuse snap ring.

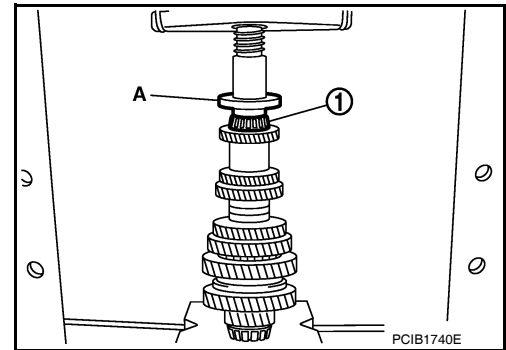

REVERSE IDLER SHAFT AND GEARS

[RS6F94R]

< SERVICE INFORMATION >

REVERSE IDLER SHAFT AND GEARS

Disassembly and Assembly

INFOID:000000007330307

DISASSEMBLY

1. Remove reverse output gear (1).

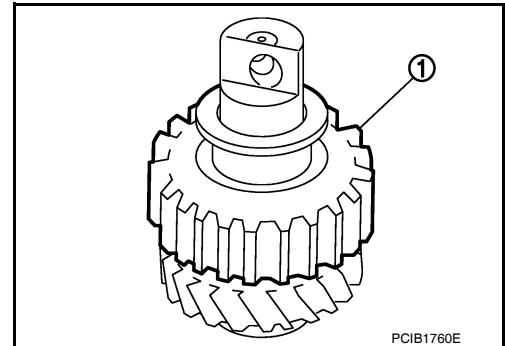

2. Remove snap ring (1) using suitable tool.

CAUTION:
Do not reuse snap ring.

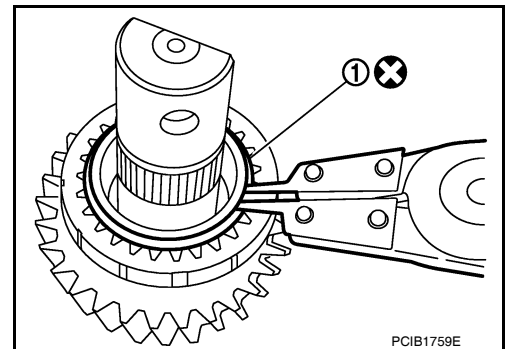

3. Remove reverse baulk ring (1) and return spring (2).

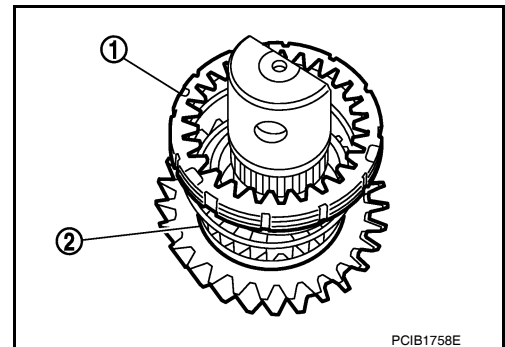

4. Remove snap ring (1), lock washer (2), and reverse input gear (3) using suitable tool.

CAUTION:
Do not reuse snap ring.

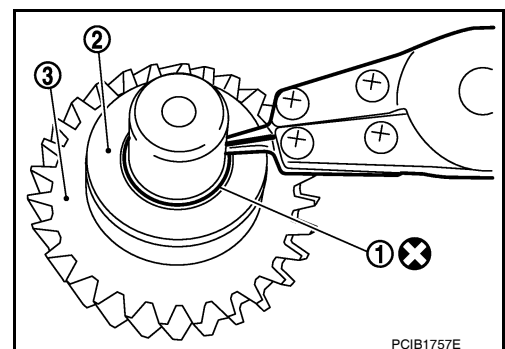

A
B
MT
D
E
F
G
H
I
J
K
L
M
N
O
P

REVERSE IDLER SHAFT AND GEARS

[RS6F94R]

< SERVICE INFORMATION >

5. Remove needle bearings (1) and spacer.

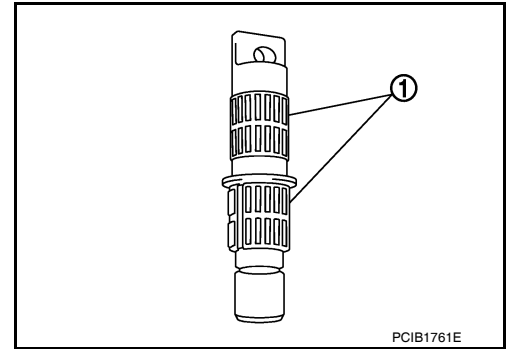

INSPECTION AFTER DISASSEMBLY

Shaft and Gear

Check the following items. Replace reverse output gear, snap ring, reverse baulk ring, return spring, needle bearing, reverse idler shaft, spacer, reverse input gear, and lock washer as a set, if necessary.

- Damage, peeling, bend, uneven wear, and distortion of shaft
- Excessive wear, damage, and peeling of gear

Bearing

Check damage and rotation of bearing. Replace reverse output gear, snap ring, reverse baulk ring, return spring, needle bearing, reverse idler shaft, spacer, reverse input gear, and lock washer as a set, if necessary.

ASSEMBLY

Note the following procedures, and assemble in the reverse order of disassembly.

CAUTION:

- **Do not reuse snap ring.**
- **Check that snap ring is securely installed in a groove.**
- **Replace reverse output gear, snap ring, reverse baulk ring, return spring, needle bearing, reverse idler shaft, spacer, reverse input gear, and lock washer as a set.**

FINAL DRIVE

Disassembly and Assembly

INFOID:000000007330308

DISASSEMBLY

1. Remove differential side bearing inner race (clutch housing side) (1) according to the following procedures.
 - a. Set a suitable tool to differential side bearing inner race (clutch housing side).
 - b. Remove differential side bearing inner race (clutch housing side) using Tool (A).

Tool number (A): ST33061000 (J-8107-2)

2. Remove speedometer drive gear.

3. Remove final gear bolts, and then remove final gear (1).

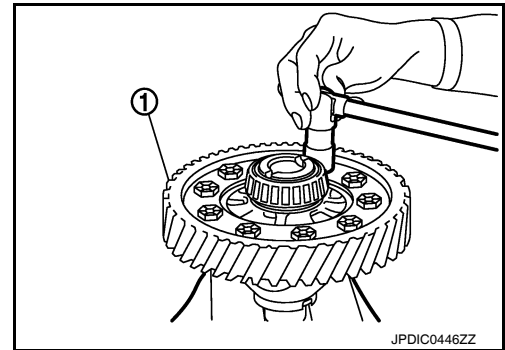
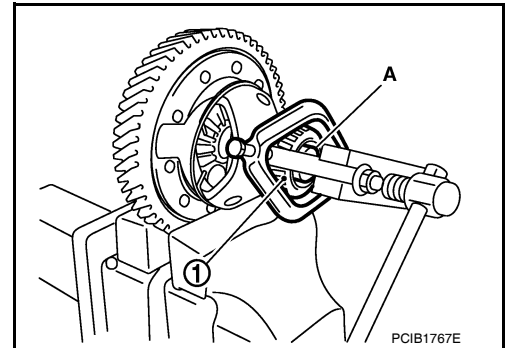

4. Remove differential side bearing inner race (transaxle case side) (1) according to the following procedures.
 - a. Set a suitable tool to differential side bearing inner race (transaxle case side).
 - b. Remove differential side bearing inner race (transaxle case side) using a suitable tool (A).

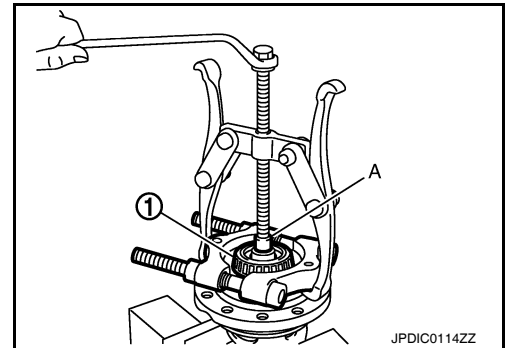

INSPECTION AFTER DISASSEMBLY

Gear and Case

Check final gear and differential case. Replace if necessary.

Bearing

Check bearing for damage and rough rotation. Replace if necessary.

CAUTION:

- Replace differential side bearing outer race (clutch housing side) and differential side bearing inner race (clutch housing side) as a set.
- Replace differential side bearing inner race (transaxle case side) and differential side bearing outer race (transaxle case side) as a set.

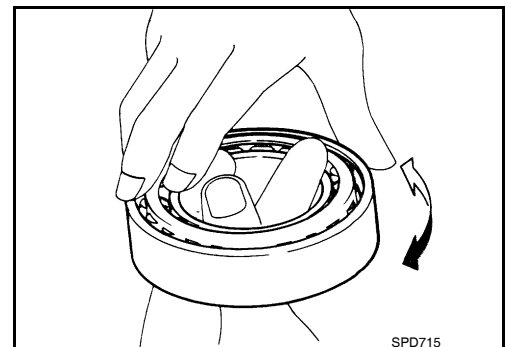

ASSEMBLY

A
B
MT
D
E
F
G
H
I
J
K
L
M
N
O
P

FINAL DRIVE

[RS6F94R]

< SERVICE INFORMATION >

1. Install final gear, and then tighten final gear bolts to the specified torque. Refer to [MT-49, "Disassembly and Assembly"](#).

CAUTION:

Replace final gear and differential case as a set.

2. Install speedometer drive gear.
3. Install differential side bearing inner race (clutch housing side) using a suitable tool (A).

CAUTION:

Replace differential side bearing inner race (clutch housing side) and differential side bearing outer race (clutch housing side) as a set.

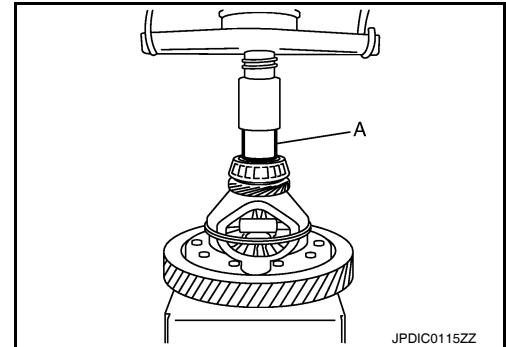

4. Install differential side bearing inner race (transaxle case side) using a suitable tool (A).

CAUTION:

Replace differential side bearing inner race (transaxle case side) and differential side bearing outer race (transaxle case side) as a set.

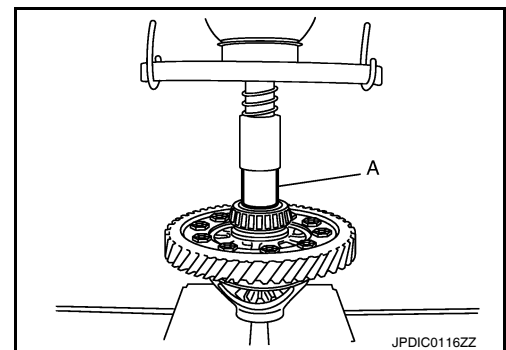

SHIFT CONTROL

Inspection

INFOID:000000007330309

FORK ROD AND SHIFT FORK

Check contact surface and sliding surface for excessive wear, uneven wear, bend, and damage. Replace if necessary.

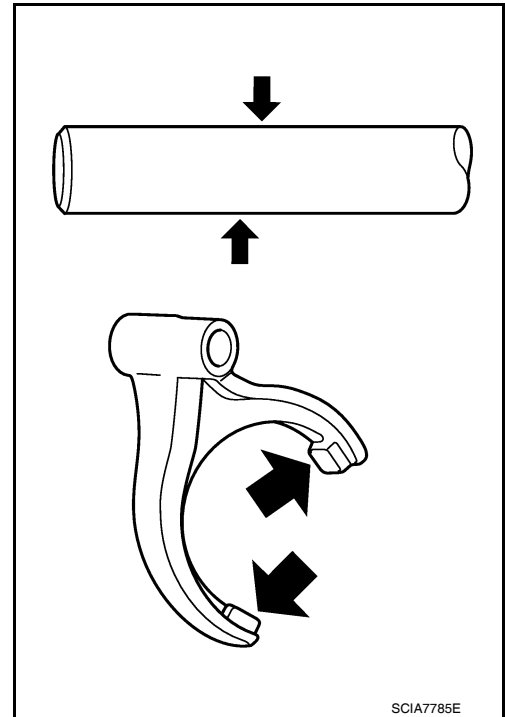

A

B

MT

D

E

F

G

H

I

J

K

L

M

N

O

P

SERVICE DATA AND SPECIFICATIONS (SDS)

< SERVICE INFORMATION >

[RS6F94R]

SERVICE DATA AND SPECIFICATIONS (SDS)

General Specification

INFOID:000000007330310

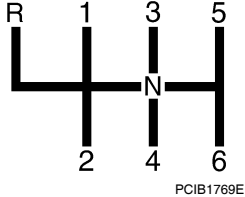
Transaxle type		RS6F94R	
Engine type		MR18DE	
Number of speed		6	
Synchromesh type		Warner	
Shift pattern			
Gear ratio	1st	3.727	
	2nd	2.105	
	3rd	1.452	
	4th	1.171	
	5th	0.971	
	6th	0.811	
	Reverse	3.687	
	Final gear	3.933	
Number of teeth	Input gear	1st	11
		2nd	19
		3rd	31
		4th	35
		5th	35
		6th	37
		Reverse	11
	Main gear	1st	41
		2nd	40
		3rd	45
		4th	41
		5th	34
		6th	30
		Reverse	42
	Reverse idler gear	Input/Output	28/29
	Final gear	Final gear/Pinion	59/15
		Side gear/Pinion mate gear	21/18
Oil capacity (Reference)		ℓ (US pt, Imp pt)	Approx. 2.0 (4-1/4, 3-1/2)
Remarks	Reverse synchronizer		Installed
	Triple-cone synchronizer		1st and 2nd